

ERGONOMIC. CLUTTER-FREE. PRODUCTIVE.



OVER 50 YEARS
OF CONTINUOUS INNOVATION.



Ebco was founded in 1963 as a Tool Room and diversified into mass production of critical components such as Cartridge Links for Ordnance Factories. In 1987, Ebco diversified into furniture hardware and has since become India's leading manufacturer of intelligent home and office furniture fittings.

Today, Ebco's product range spans Office Furniture Fittings, Drawer Slides and Hinges, General Hardware, Joinery Fittings & Screws, Furniture Locks, Retail Display Systems, Window-Door & Glass Hardware, Kitchen Systems & Accessories, Aluminium Profiles & Handles, Bed & Wardrobe Fittings & Accessories, Furniture Lights – LED. Our strengths include a range of core competencies in manufacturing, an ever-widening product range, stringent quality standards, affordable prices and an all-India distribution network.



Palghar Factory



Plant 1 - Vasai



Plant 3 - Palghar

INFRASTRUCTURE

We have a state of the art design and product development department which uses the latest 3D design software and CNC Machining Technology. This enables us to launch many new products every month. Our Tool Room capacities have increased significantly which has reduced product development lead time. Our corporate office is located in India's financial capital, Mumbai; we have three manufacturing plants and multiple warehousing facilities north of Mumbai in the towns of Vasai and Palghar, Maharashtra.

Our plants use state-of-the-art roll forming and sheet metal pressing technology. Our products are engineered to perform and our quality department helps ensure that we consistently achieve this goal. Our Quality Assurance Laboratory at the Vasai manufacturing plant performs rigorous cycle tests, load tests and other checks in accordance with certified international quality norms. Our Window Fittings Plant in Palghar has been expanded to increase production capacity and we have commissioned two new warehouses in Palghar which have significantly increased our storage capacity.



Roll Forming Production Line



Design & Development Dept



Press Shop - Unit 2

PRODUCT RANGE

Our products are organised in to 11 verticals under 3 brands, each of which are unique, comprehensive and satisfy a variety of requirements.

WORKSMART – ERGONOMIC HARDWARE FOR OFFICES

Already a market leader in this category, we continue to offer great products to facilitate better working habits and enhance productivity. Our Office Furniture Fittings segment includes a variety of new Monitor Arms, Smart Lifts – Height Adjustable Desks, Computer Keyboard Stations, CPU Stations, Cable Organisers and other accessories.

EBCO – SIMPLIFYING LIVES

Known for quality with value for money pricing and a wide range, we truly embody the drive to Make in India – we make almost all products under 7 verticals at our plants here in India. Over the past two years, we have significantly widened our range of products with a special focus on the Architectural Hardware and Window Fittings segments. Our newly introduced products include Pole Display Shelving System, Steelfix, Combination Locks, Drawer Slides & Hinges, Friction Stays, Sliding Window Locks and many more.

LIVSMART – INTELLIGENT HARDWARE FOR HOMES

Our Kitchen Systems and Accessories segment includes Drawer Systems and Accessories, Corner Solutions, Overhead Systems, Midway Systems, Waste Bins, Roll Top Shutters and more. With a special focus on strengthening our Bedroom Furniture Fittings segment we have widened our range of products which includes Wardrobe Sliding Systems and Accessories, Pro Lift & Electric Bed Fittings and related products.

Our strengths in these segments include our broad product range, best-in-segment quality standards, cutting edge features and fair pricing.



Rain Water Harvesting Tank Below Front Lawn – Unit 1 Vasai



Rooftop Solar Panels at Unit 2 Palghar



Ebco Factory Garden

CERTIFICATIONS

Quality products, the protection of our environment and nurturing our people have always been our priorities.

As a company, we are BIFMA Compliant. Our manufacturing plant at Vasai houses our Design and Development department, Tool Room, Press Shop, Hardening, Phosphating and Assembly departments and has been certified in ISO 9001: 2015 – Quality Management System, ISO 14001: 2015 – Environmental Management System, ISO 45001:2018 – Occupational Health and Safety Management System.



ISO 9001: 2015 Quality Management Systems

ISO 14001: 2015 Environmental Management Systems

ISO 45001 : 2018 Occupational Health and Safety Management Systems

BIFMA

Our products are BIFMA compliant.



BIS Certification

www.bis.gov.in

Bureau of Indian Standards





WORKSMART FITTINGS FOR OFFICE FURNITURE.



At Ebco, we believe that all spaces are different. We approach workspaces with the goal of making them productive, efficient and healthy for your most important resource – human capital. Worksmart is our exclusive range of fittings for office furniture.

Developed at our recently upgraded and state-of-the-art manufacturing plants, through continuous in-house R&D and our experience as a market leader in India, these fittings are truly world-class and set the benchmark for Indian workspaces.

MAKES LIFE



"TICKMAN"
THE HALLMARK
OF EFFICIENCY





CONTENTS

ERGONOMICS@WORK™	10
THE SMARTEST WAY TO STUDY AND WORK FROM HOME!	12
GET ORGANISED - WITH WORKSMART FITTINGS	14
STAND UP FOR YOUR HEALTH	16
SMART LIFTS	18
COMPUTER MONITOR ARMS	34
FLAT SCREEN HOLDERS	40
ARTICULATED KEYBOARD STATION	41
KEYBOARD TRAYS	42
CPU STANDS.....	44
SAFE DRAWERS.....	46
OFFICE FURNITURE ESSENTIALS.....	52
ELECTRIC BOXES & CHARGERS.....	55
CABLE ORGANISERS.....	61



Ergonomics is the science of making spaces work well for people who use them. It is the understanding of how an office environment best interfaces with human use and productivity. Comfort and ease-of-use of office furniture primarily depend on the fittings and accessories that are used with them.

A stylized line-art illustration of a home office. It features a desk with a laptop, a chair, and a potted plant on a stand. The background is a solid light blue color.

Working and studying from home are here to stay. To be productive from home and stay pain-free after all those hours, you need an ergonomic #WorkFromHome height adjustable desk, and a set of essential accessories to keep you organized and your space clutter free.

Choose from a wide range of SmartLifts and other ergonomic products to build your own #SmartDesk today.

Ebco leads the way with its innovations through Worksmart Fittings for office furniture. Products such as Smart-Lift Height Adjustable Desks, Monitor Arms, Articulated Keyboard Stations, CPU Stations, easy-access under or above desk charging stations and Safe Drawers are just some of the many products that revolutionize workspaces and enable people to work better.





With Worksmart Fittings and Accessories.

As families try to adapt and adjust to lockdown conditions, home is becoming the only space from where all activities are being conducted. For adults and children. For office work, schoolwork, entertainment and leisure. Worksmart offers the perfect solutions to make your home truly work for each of these needs. The father's work desk for online meetings, the child's school desk for online classes or music lessons, and even a space for setting up the family's home entertainment centre!

Choose from a wide variety of options, from the simple laptop stand and table bracket to the more elaborate Smart Lift Desk, pole shelving systems that can provide table and shelf spaces in one unit, accessories such as charging stations and extension USB ports, almost everything that makes it convenient to work from home for adults and do homework for kids!

#WFH#Worksmart – The smartest was to do your Homework!

THE SMARTEST WAY TO STUDY AND WORK FROM HOME!

10 am
presentation



10 am
teaching



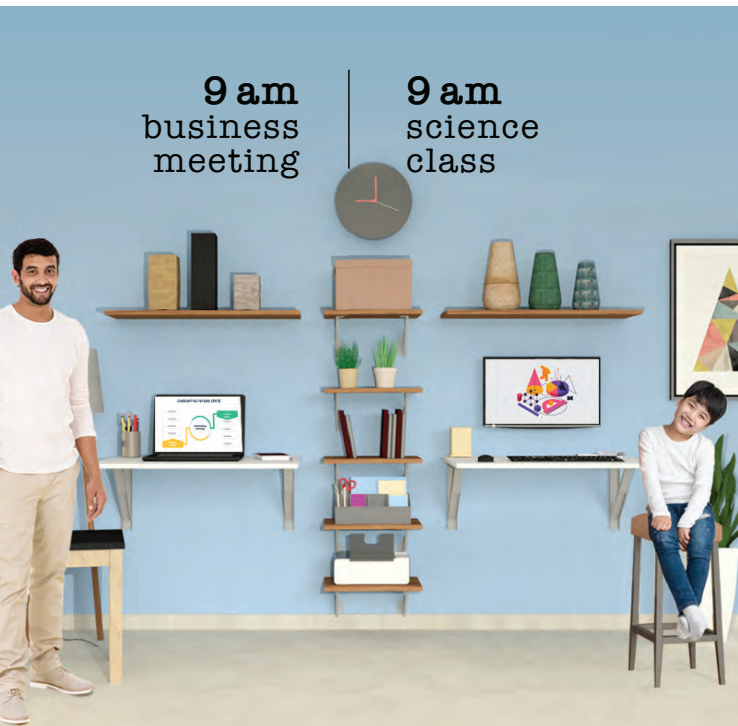

GET ORGANIZED...



Clutter is associated with anxiety, stress and lost time spent trying to look for things lost in a mess. Ebco cuts the clutter with a variety of solutions that keep even the smallest of desks organized without compromising on functionality. With less desk space, you can still have more 'work' space. As illustrated above, get more work space from the same desk.

...WITH WORKSMART FITTINGS!



A height adjustable desk allows you to stand when you feel sluggish or sit at a comfortable height. A monitor arm allows you to adjust the monitor to the height and angle that you prefer. Vertebrae keep those messy wires neat and out of sight and a table edge mount charging station ensures that you don't have to go hunting under your desk for power.

Less is more. This is the magic of Worksmart.

STAND UP FOR YOUR HEALTH

Continuously working at your desk in a sitting position leads to poor posture and stress on your muscles and spine. Research shows that for every 45 minutes of sitting, we need to take a break and stretch for 5



ERGONOMICS@WORK™

minutes. Worksmart Smart-Lift Desks are the perfect solution in enabling you to work sitting down or standing up, at the exact height that suits your body!



SMART LIFTS

SMART LIFT PRO 2

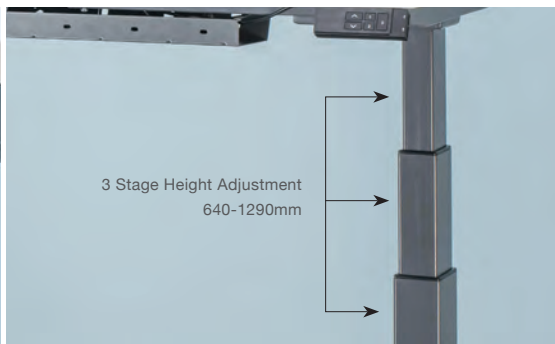
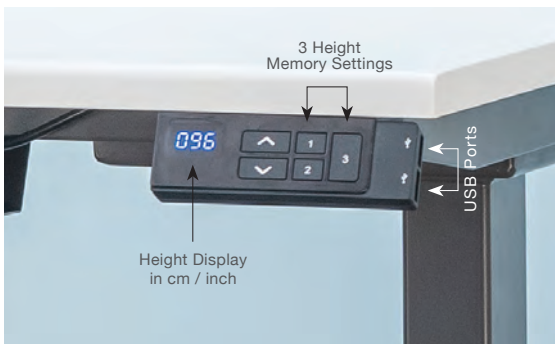

1 SLTLP2 - E



- Dual Motor.
- Anti-collision sensors and safety control.
- 3 Stage rectangular legs.
- 3 Height Memory Setting.
- Height (in cm / inch) Display.
- 2 USB ports for mobile phone charging.
- Width Adjustment: 1075-1800mm.
- Height Adjustment: 640 – 1290mm.
- Display Height Range: 660 - 1310mm (Considering Table Top)
- Speed – 40mm/sec.
- Max. Load: Static – 200KGS / Dynamic - 120KGS.
- Input Power: 220-230 V / 50-60 Hz / 2S A
- Noise Level: < 50 dB (A)
- Finish : White / Anthracite

How to set height memory setting:

- Adjust the table to desired height using arrow keys (Up/ Down).
- Press 'Up' arrow key with key '1' to save height on key '1' (Display blinks 'P1' on saving height)
- Repeat step 1 & 2 to save height on key 2 & 3 respectively.

How to operate using the saved height:

Single tap the key 1 or 2 or 3 with the saved height to use / adjust.

* Table top options available. Please check Page 20.

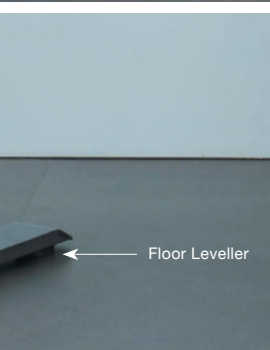
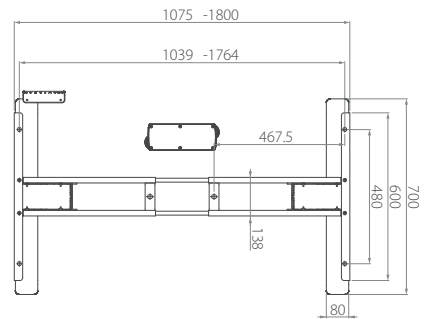
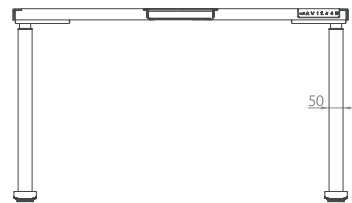
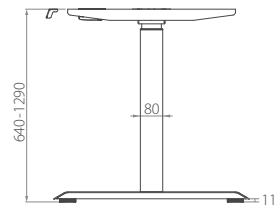
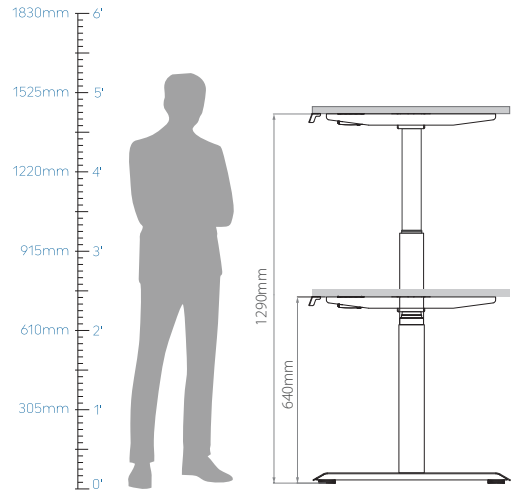

Floor Leveller



TABLE TOP

FOR SMART LIFT PRO 2 / SMART LIFT ELECTRIC - 2

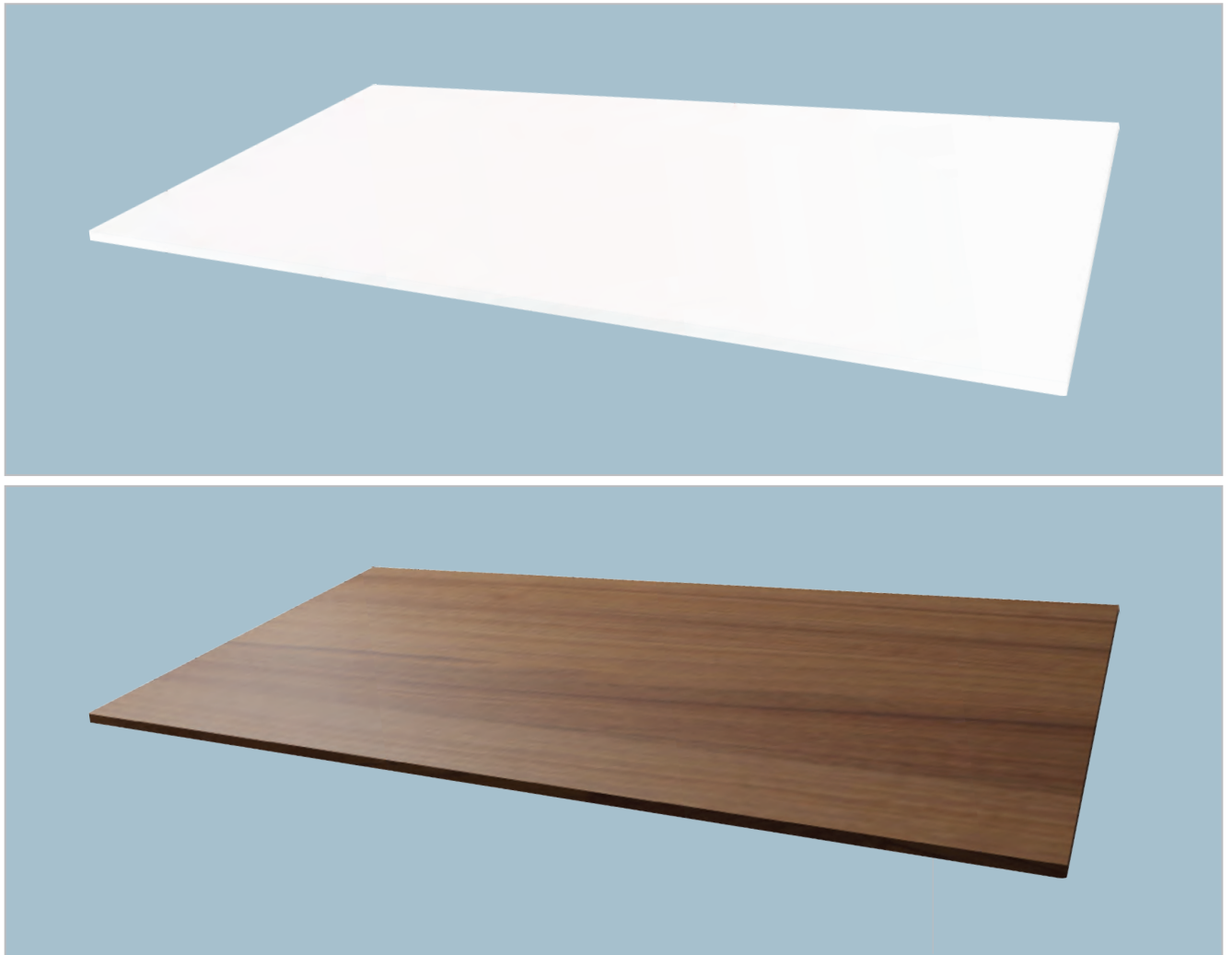

Features:

- Ready-to-mount tops are designed for use with our range of Smart Lift Height Adjustable Desk Legs by WorkSmart (to be purchased separately)
- They are made of pre-laminated Medium Density Fibreboard (MDF)
- Available in 2 sizes:
Depth 750mm x Width 1200mm x Thickness 18mm
Depth 750mm x Width 1500mm x Thickness 18mm
- Available in two finishes: Frosty White (FW) and Classic Walnut (WN)

Item	Code	Size (mm)	Compatible Smart Lift	Finish
Table Tops for Smart lifts -18mm	SLTT1-75120FW	750 x 1200 x 18 mm	SLTLP2 - E / SLTL2 - E	Frosty White
	SLTT1-75150FW	750 x 1500 x 18 mm	SLTLP2 - E / SLTL2 - E	Frosty White
	SLTT1-75120WN	750 x 1200 x 18 mm	SLTLP2 - E / SLTL2 - E	Classic Walnut
	SLTT1-75150WN	750 x 1500 x 18 mm	SLTLP2 - E / SLTL2 - E	Classic Walnut

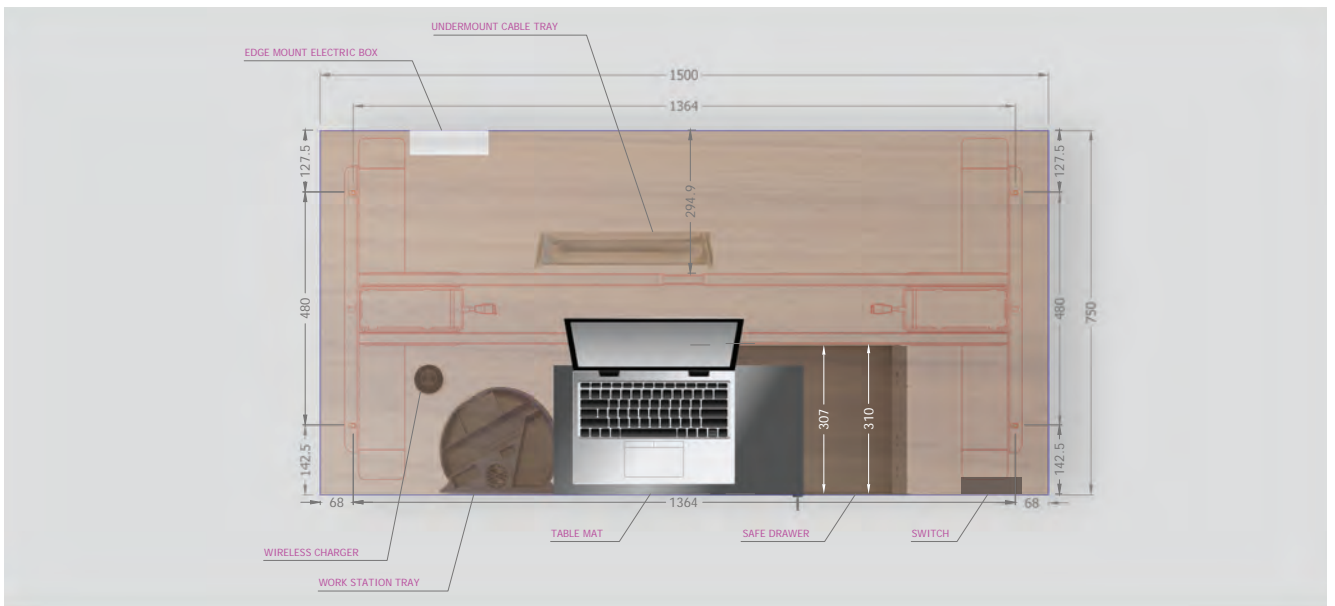
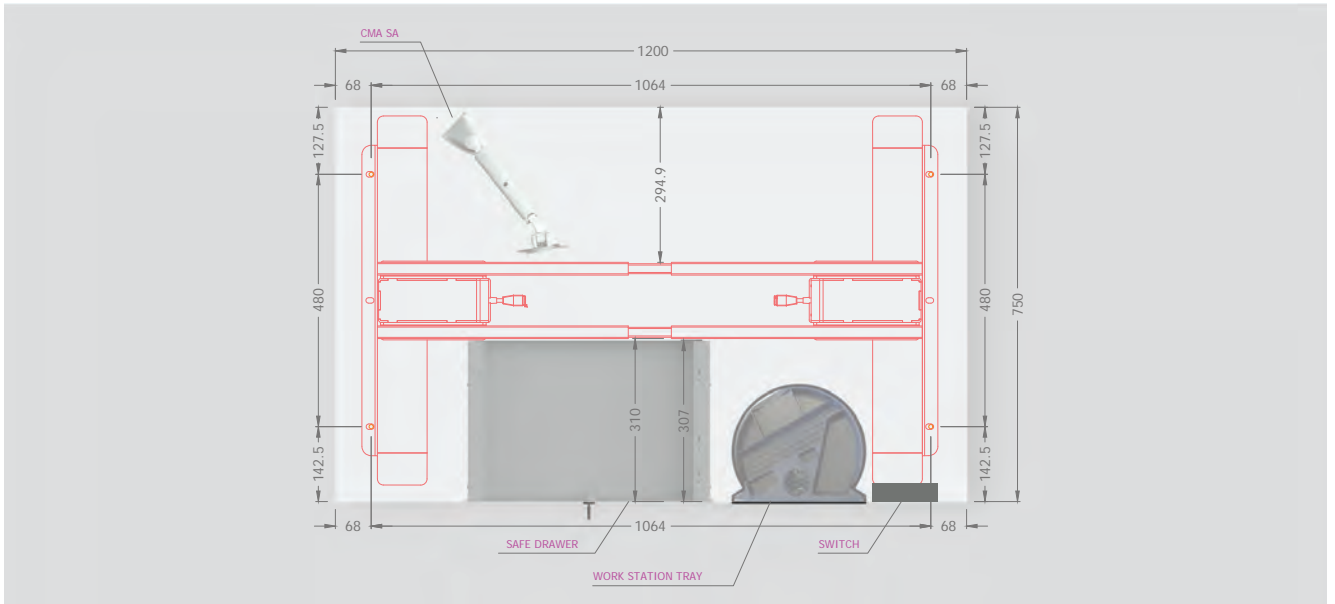

WORK STATION TRAY - ROUND



Please see page no: 52

TABLE MAT



Please see page no: 52

WIRELESS CHARGER



Please see page no: 60

COMPUTER MONITOR ARM SINGLE ARM



Please see page no: 36

SAFE DRAWER



Please see page no: 46

ELECTRIC BOX - EDGE MOUNT



Please see page no: 57

SWITCH OF SMARTLIFT PRO 2



Please see page no: 18

SWITCH OF ELECTRIC 2



Please see page no: 24

SMART LIFTS

SMART LIFT PRO 3

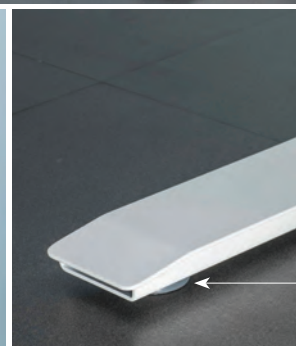

1 SLTLP3 - E (Without Table Top)



- Anti-collision sensors and safety control.
- 4 position table height memory settings.
- 3 Stage Square Legs.
- Width Adjustment: 1100 – 1600mm.
- Height Adjustment: 620 – 1090mm.
- Display Height Range: 620 – 1090mm (Considering Table Top).
- Speed: 36 ± 2 mm/sec.
- Max. Load: Static – 200KGS / Dynamic - 120KGS.
- Input Power: 100-240 V / 50-60 Hz / 350 W
- Noise Level: < 50 dB (A)
- Finish : White / Anthracite

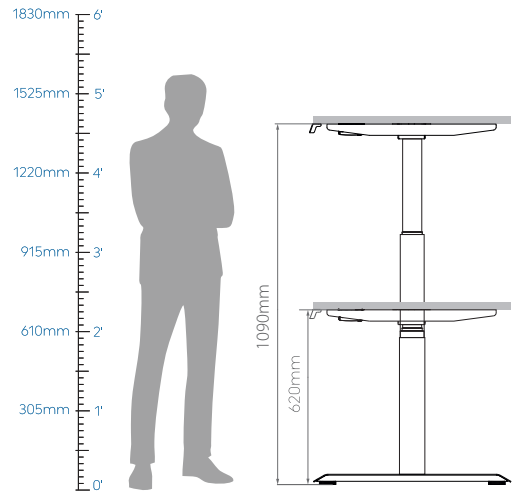

How to set height memory setting:

- Adjust the table to desired height using arrow keys (Up/ Down).
- Press key 'M' with number key '1' to save height on key '1' (Display blinks twice on saving height).
- Repeat step 1 & 2 to save height on key 2, 3 & 4 respectively.

How to operate using the saved height:

Double tap the key 1 or 2 or 3 or 4 with the saved height to use / adjust.

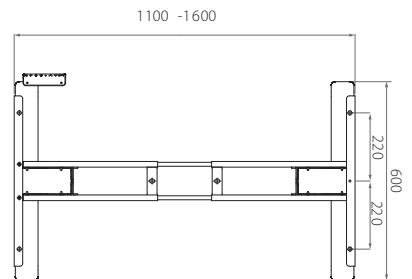
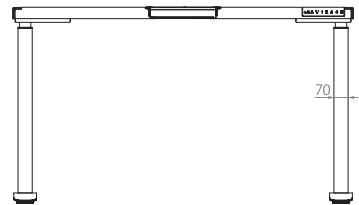
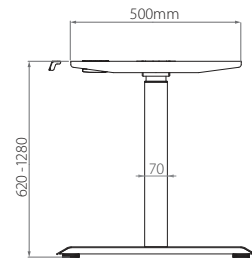

Floor Leveller

SMART LIFTS

SMART LIFT ELECTRIC 2

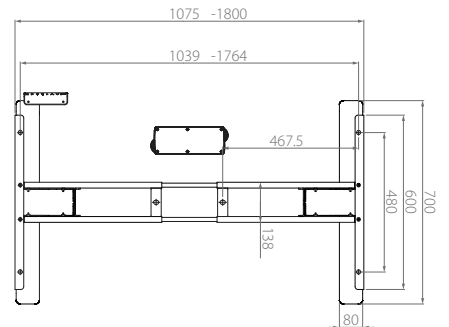
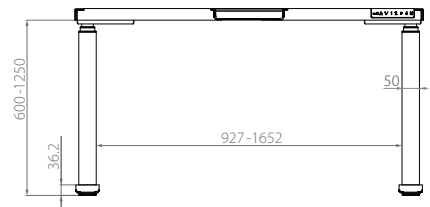
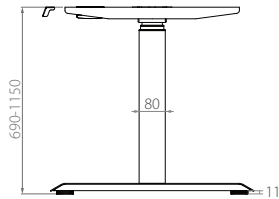
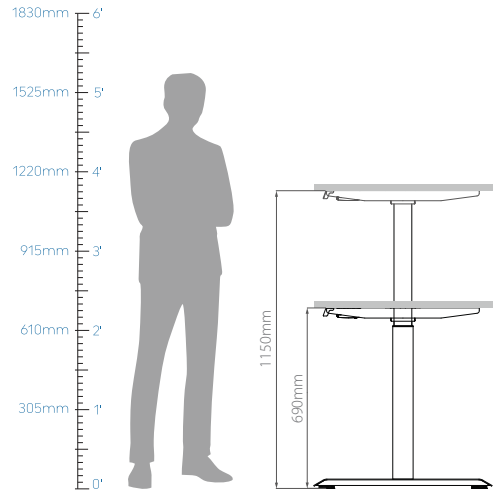

- Dual motor.
- Anti-collision sensors and safety control.
- Width Adjustment: 1075 – 1800mm.
- Height Adjustment: 690 - 1150mm.
- Display Height Range: 710 - 1170mm (Considering Table Top).
- Two stage rectangular legs.
- Speed: 32mm/sec.
- Max. Load: Static – 200KGS / Dynamic - 120KGS.
- Input Power: 220-230 V / 50-60 Hz / 2S A
- Noise Level: < 50 dB (A)
- Finish : White / Anthracite

* Table top options available. Please check Page 20

1 SLTL2 - E



SMART LIFTS

SMART LIFT ELECTRIC 3

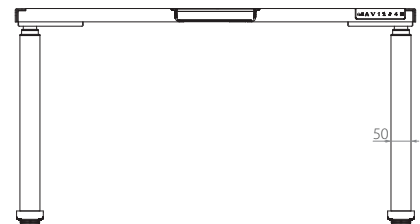
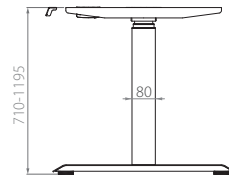
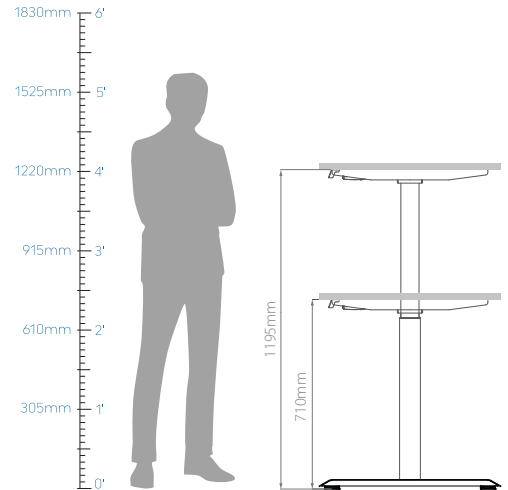

- Special dual motor to raise and lower the table height.
- Anti-collision sensors and safety control.
- Two stage rectangular legs.
- Width Adjustment: 1150 – 1600mm.
- Height Adjustment: 710 – 1195mm.
- Display Height Range: 730 – 1230mm.
- Speed: 32±2mm/sec.
- Max. Load: Static – 150KGS / Dynamic - 100KGS.
- Input Power: 100-240 V / 50-60 Hz / 250 W
- Noise Level: < 50 dB (A)
- Finish : White / Anthracite

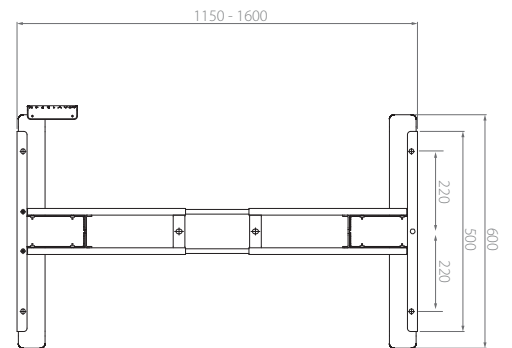

1 SLTL3 - E (Without Table Top)

SMART LIFTS

SMART LIFT ELECTRIC BASIC

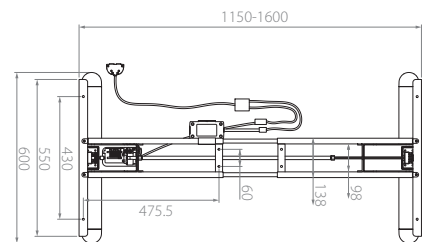
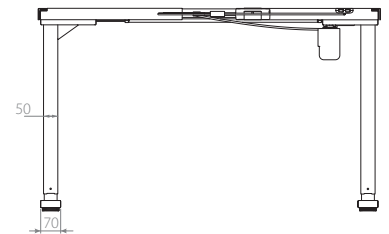
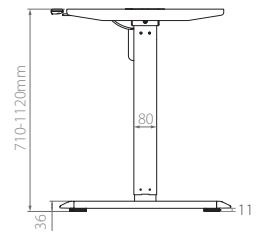
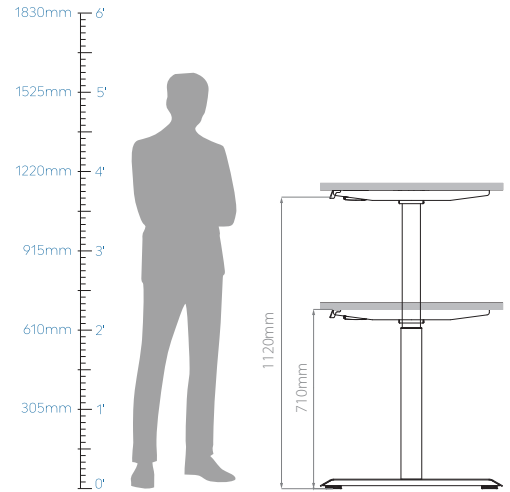

- Special single motor to raise and lower the table height.
- Height adjustment: 710-1120mm
- Width adjustment: 1150 -1600mm
- Stroke: 410mm
- Speed: 23mm/s
- Input Power: 100-240V
- Does not include table top
- Max. Load: Static-80Kgs/Dynamic-60 Kgs
- Noise level: 50db
- Finish : White / Anthracite

1 SLTLB1-E (Without Table Top)

SMART LIFTS

SMART LIFT TABLE LEGS – 1200 / 1500 GAS LIFT

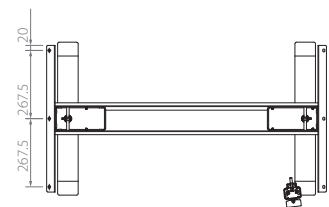
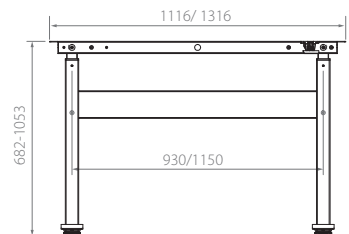
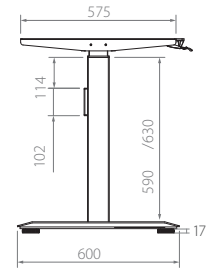
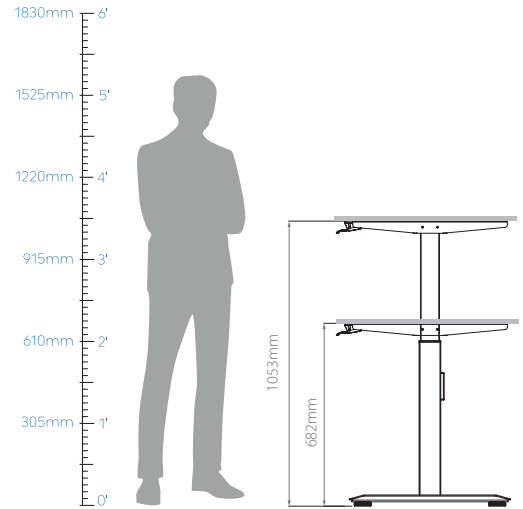

- Ergonomically designed height adjustable table legs with gas lift technology that eliminates the need for electricity or manual effort.
- Sit or stand and work comfortably with these height adjustable desks.
- Using gas lift technology these are easy to use with a press of a hand lever to adjust the height as in chairs.
- Ideal for Offices, Institutional and home applications.
- Choose from with or without table top.
- Height Adjustment: 682 - 1053mm (For both 1200/1500 width)
- Stroke: 380mm
- Speed: 200mm/s
- Capacity: Dynamic – 15kg, Static – 100kg

- Dimension:
Table Top – 1200mm x 680mm x 18mm
Frame Size – (W) 1100mm, (D) 600mm
- Mechanism Finish – Silver
- Table Top – MDF

Size (H x W x D)

- | | | |
|---|---------------------------------------|-------------------------|
| 1 | SLTL2-120G (1200 - Without Table Top) | 682 - 1053 x 1100 x 575 |
| 2 | SLTT-120 (1200 - Table Top) | 18 x 1200 x 680 |
| 3 | SLTL2-150G (1500 - Without Table Top) | 680-1060 x 1296 x 575 |

SMART LIFTS

SMART LIFT TABLE LEGS – 1200-1600 - GAS LIFT

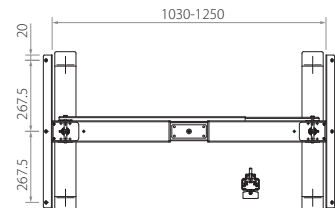
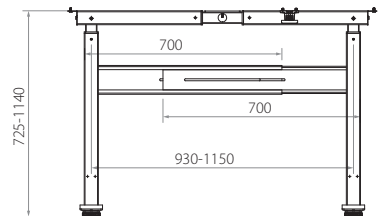
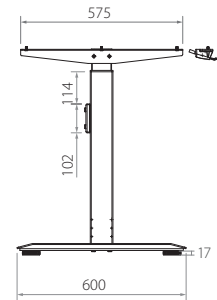
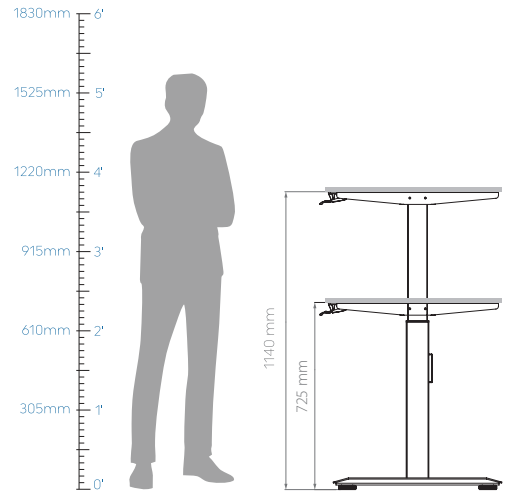

- Sit or stand and work comfortably with these heights adjustable desks.
- Using gas lift technology, these are easy to use with a press of hand lever to adjust the height as in chairs.
- Width Adjustment : 1030 - 1250mm
Height Adjustment : 725-1140mm
- Ideal for office, institutional and home applications.
- Adjustable width as per requirement from 1200 – 1600mm.
- Stroke: 380mm
- Speed: 200mm/s
- Capacity: Dynamic - 15kg, Static -100kg.
- Dimension:
Frame Size – (W) 1200-1600, (D) 600
- Mechanism Finish – Silver

1 SLTL2-120-160G (Without Table Top)

SMART LIFTS

SMART LIFT SINGLE LEG – GAS LIFT (CENTRE POLE)

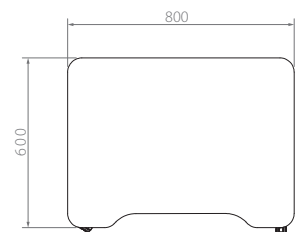
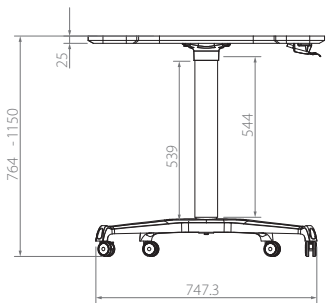
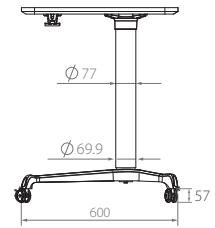
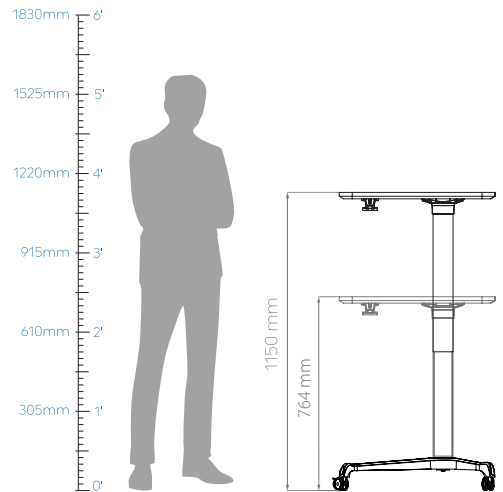

- Sit or stand mobile work desk with height adjustment feature.
- Single pole structure with built-in castors enables easy movement of workstation.
- Raise or lower the desk at any desired height with in-built hand lever.
- Ideal for Offices, Institutional and home applications.
- Optional plinth levellers available instead of Castors. (On request)
- Available with table top
- Height: 764 – 1150mm
- Stroke: 390mm
- Speed: 200mm/s
- Capacity: Dynamic – 8kg, Static – 50kg
- Dimension:
Table Top – 800mm x 600mm x 25mm
Frame Size – (W) 748mm, (D) 600mm
- Mechanism Finish – Silver
- Table Top – MDF

1 SLSL2 GTT - CP (With Table Top)

SMART LIFTS

SMART LIFT SINGLE LEG - GAS LIFT (CENTRE POLE - ROUND)

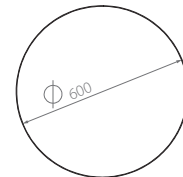
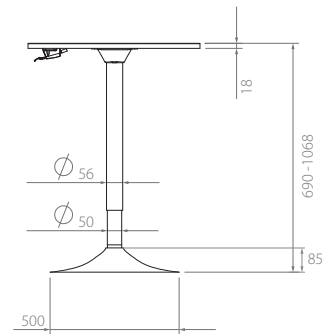
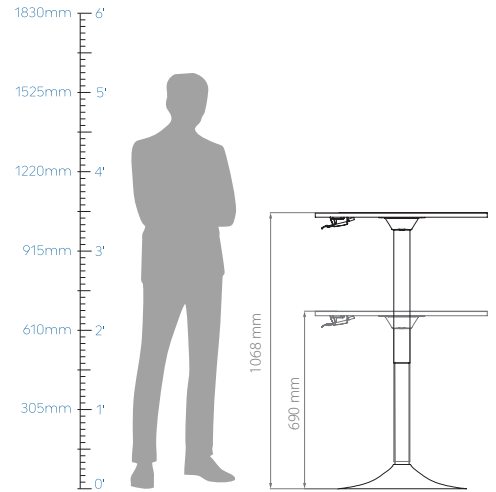

- Sit or stand and work comfortably with these height adjustable desks.
- Easy to use with a press of hand lever to adjust the height as in chairs.
- Ideal for offices, institution and home applications.
- Stroke: 380mm
- Speed: 200mm/s.
- Capacity: Dynamic - 15 kg, Static - 100 kg
- Height Adjustment : 690-1065mm
- Dimension:
Table Top - Ø 600 x 18 mm
Frame Size - Ø 500 x (H) 685-1065
- Finish - White

1 SLSL2 GTT – CP2 (With Table Top)

SMART LIFTS

SMART LIFT SINGLE LEG - GAS LIFT (CENTRE POLE 3)

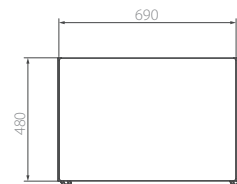
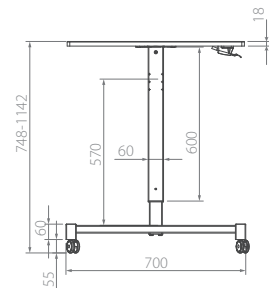
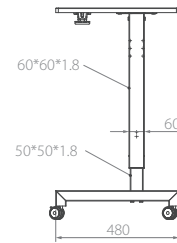
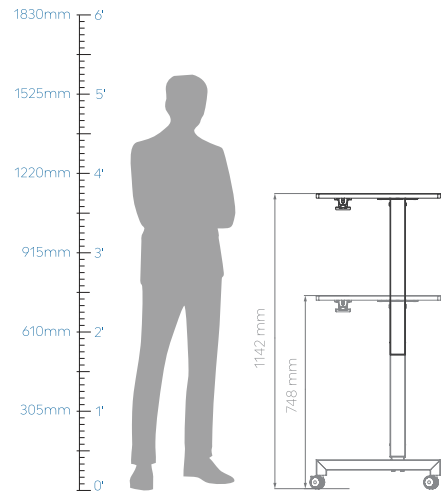

- Ideal for offices, institutions and home applications.
- Raise or lower the desk at any desired height with in-built hand lever.
- Single pole structure with built-in castors enables easy movement.
- Height adjustment: 748 – 1142mm
- Table top size: 690 x 480 x 18mm
- Stroke: 394mm
- Load capacity:
Dynamic - 5Kg, Static – 50kg
- Finish: White

1 SLSL2-GTT-CP3 (With Table Top)

SMART LIFTS

SMART LIFT FOLDING TABLE - GAS LIFT (WALL MOUNT)

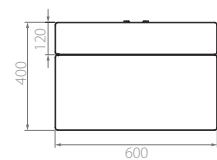
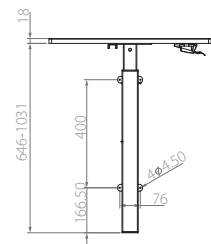
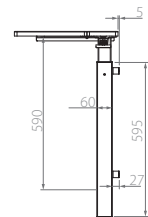
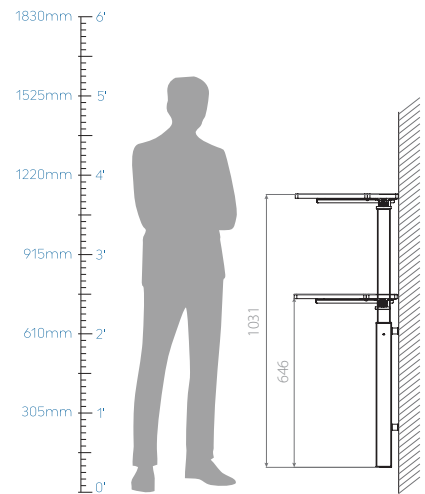

- Smart lift gas lift is now available with foldable wall mount variation.
- Ideal for multiple applications such as home, offices, etc.
- Raise or lower the desk at any desired height with in-built hand lever.
- Special release knob helps to fold the table.
- Height adjustment: 646 – 1031mm
- Table top size: 600 x 400 x 18mm
- Stroke: 375mm
- Load capacity: Dynamic - 4Kg, Static – 40kg
- Finish: Black/ White

1 SLFT-GTT-WM (With Table Top)

SMART LIFTS DRAWING TABLE

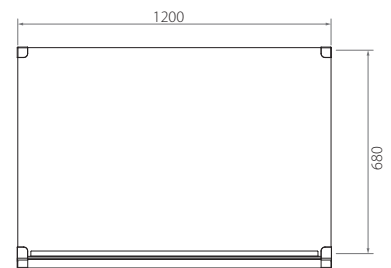
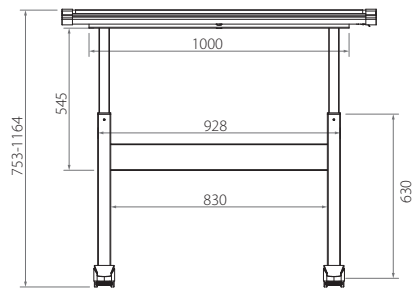
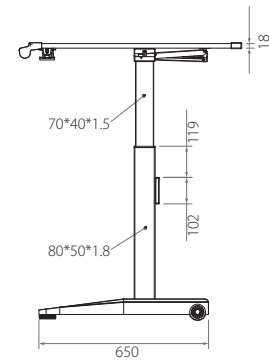
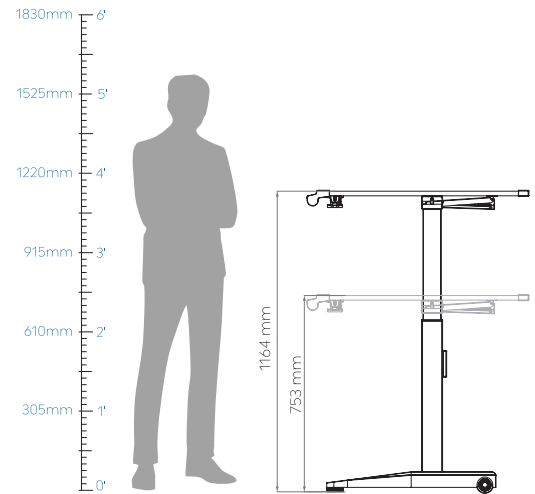

- Ideal for offices, institutional and home applications
- Comes with table top
- Pencil / Accessories tray attached
- Height Adjustment : 753 – 1164mm
- Load Capacity :
Dynamic – 15kg, Static – 100kg
- Top angle adjustment up to 45° (8 step)
- Table-Top size: 1200 (W) x 680 (D) x 18 (T)

1 SLDT-120G (With Table Top)

COMPUTER MONITOR ARMS

TWIST, TURN & LIFT TO ANY POSITION

Now you don't need to turn or twist your body or keep lifting your head up! The Worksmart Single and Dual Monitor Arms will move the screen to whichever position suits your posture, with as many changes as you like!

CMA SINGLE ARM / SINGLE EXTENDED ARM EDGE MOUNT

- **Flexible height adjustable** monitor arms, available in different variants - Single Arm, Single Arm Extension, Single Arm Wall Mount, Single Extended Arm Wall Mount, Single Arm Edge Mount, Single Arm Extension Edge Mount, Double Arm, Double Arm Extension, Laptop Plate.
- **Angular adjustment** enables comfortable working thereby reducing neck, eye and back strain.
- **Rotation of screen** from landscape to portrait mode to view documents without scrolling.
- **Ease of sharing** screen with co-workers with just a simple tilt.
- **Concealed cable management** system enables clutter free work desk.
- **Practical solution** for commercial spaces, security offices, health care environments etc.
- **Compatible** for VESA 75 x 75 and VESA 100 x 100.
- **Load Capacity** - 6 kgs per arm.
- **Finish:** White Texture, Anthracite

1 CMA - SA

2 CMA - EAEM / CMA - SAEM



CMA SINGLE ARM EDGE MOUNT

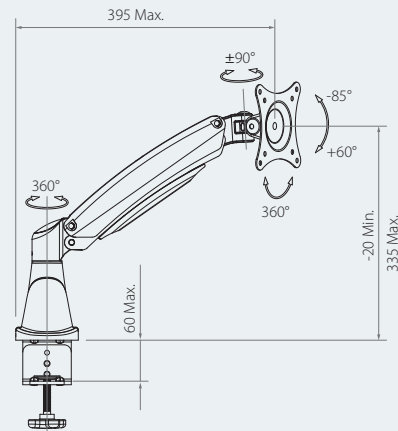

CMA SINGLE EXTENDED ARM EDGE MOUNT

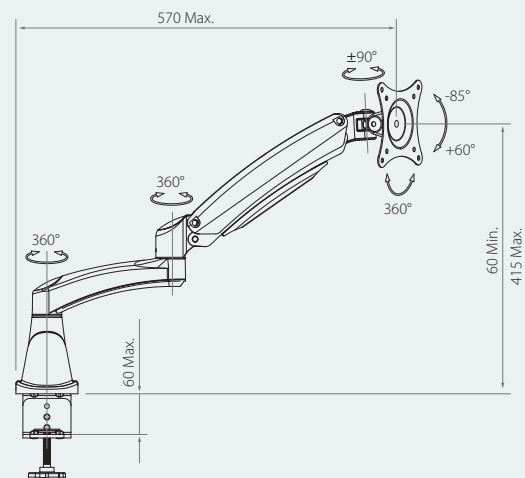



2



EDGE MOUNT APPLICATION



TILT RANGE
+60° to -85°



SWIVEL RANGE
360°



SCREEN ROTATION
360°



EXTENSION
570mm



VESA COMPATIBLE
75 X 75 & 100 X 100



SCREEN SIZE
15" to 27"



CONCEALED WIRE MANAGEMENT



LOAD CAPACITY
6kg/arm

COMPUTER MONITOR ARMS

CMA SINGLE ARM

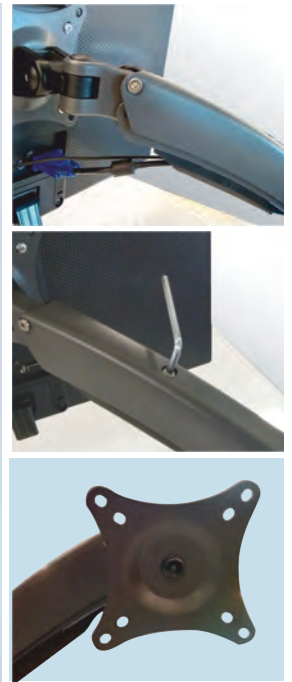

- Robotic arm design enables flexibility for practical view.
- Table Top Grommet mounting for 15" to 27" screen.
- Compatible for VESA 75 X 75 & VESA 100 X 100.
- Load Capacity: 8 kg per arm.
- Finish: White Texture, Anthracite.

1 CMA - SA

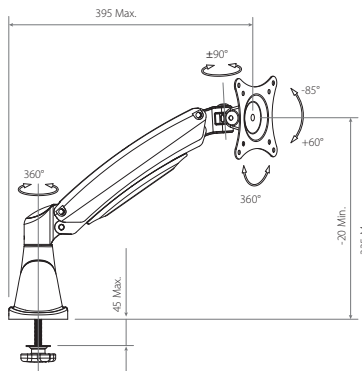

DESK MOUNT APPLICATION



TILT RANGE
+60° to -85°



SWIVEL RANGE
360°



SCREEN ROTATION
360°

CMA SINGLE ARM - EXTENSION

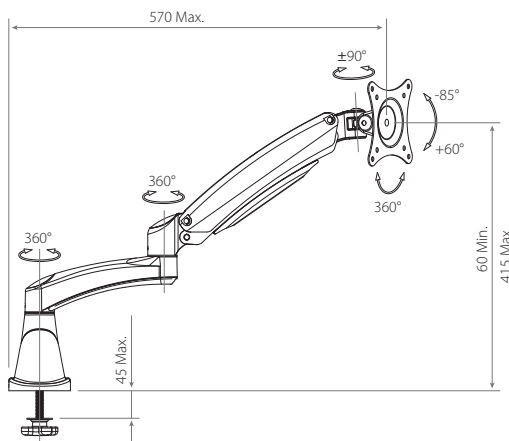

EXTENSION
395mm/570mm

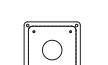

VESA COMPATIBLE
75 X 75 & 100 X 100



SCREEN SIZE
15" to 27"



CONCEALED WIRE MANAGEMENT



LOAD CAPACITY
8kgs/arm

2 CMA - EA

COMPUTER MONITOR ARMS

CMA DOUBLE ARM - EDGE MOUNT

DOUBLE ARM-EDGE MOUNT EXTENSION



3 CMADA – EM

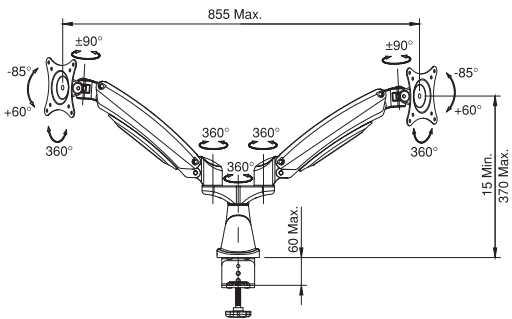

4 CMADA – EAEM

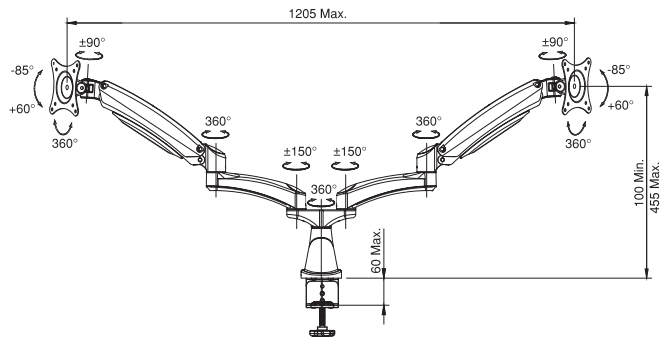

DESK MOUNT APPLICATION



TILT RANGE
+60° to -85°



SWIVEL RANGE
+90° to -90°



SCREEN ROTATION
360°



VESA COMPATIBLE
75 X 75 & 100 X 100



SCREEN SIZE
15" to 27"

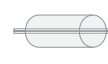

CONCEALED WIRE MANAGEMENT



LOAD CAPACITY
6kgs/arm

CMA LAPTOP PLATE (OPTIONAL)

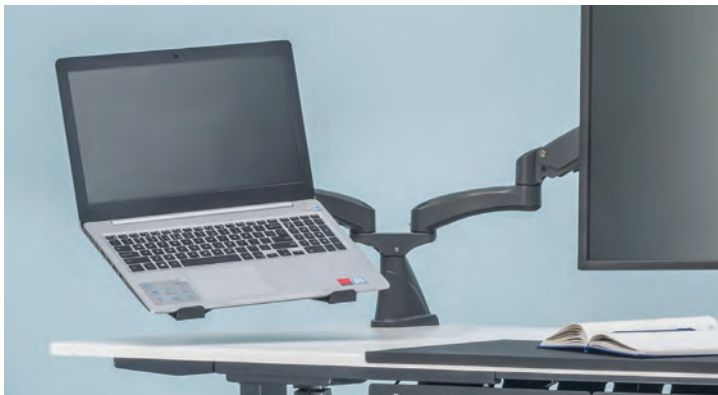

- These height adjustable monitor arms are highly flexible, productive and convenient to operate.
- Rotation of screen from landscape to portrait enables easy view of documents without scrolling.
- Ease of sharing screens with co-workers with just a simple tilt.
- Table Top Grommet Mounting for 15" to 27" screen.
- Compatible for VESA 75 x 75 and VESA 100 x 100.
- Load Capacity - 8 kgs per arm.
- Finish: White Texture, Anthracite.

5 CMA - LB

COMPUTER MONITOR ARMS

CMA DOUBLE ARM



6 CMA - DA

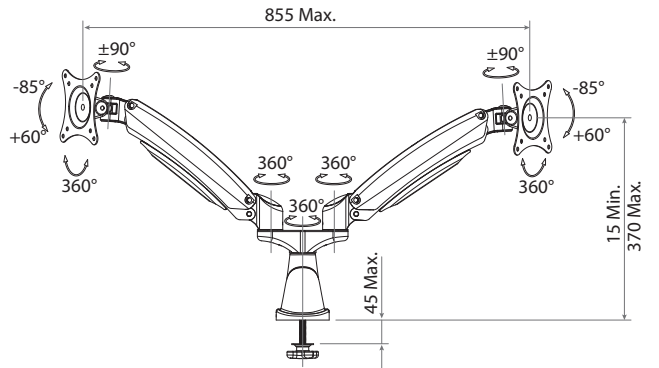

DOUBLE ARM - EXTENSION



7 CMA - DEA

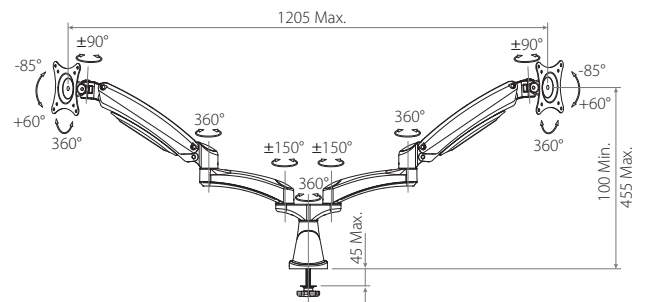

- These height adjustable monitor arms are highly flexible, productive and convenient to operate.
- Rotation of screen from landscape to portrait enables easy view of documents without scrolling.
- Ease of sharing screens with co – workers with just a simple tilt.
- Table Top Grommet Mounting for 15” to 27” screen.
- Compatible for VESA 75 x 75 and VESA 100 x 100.
- Load Capacity - 8 kgs per arm.
- Finish: White Texture, Anthracite.



DESK MOUNT APPLICATION



TILT RANGE
 $+60^\circ$ to -85°



SWIVEL RANGE
 $+90^\circ$ to -90°



SCREEN ROTATION
 360°



VESA COMPATIBLE
75 X 75 & 100 x 100



SCREEN SIZE
15” to 27”

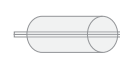

CONCEALED WIRE MANAGEMENT



LOAD CAPACITY
8kgs/arm

COMPUTER MONITOR ARMS

CMA SINGLE ARM WALL MOUNT



8 CMA-SAWM

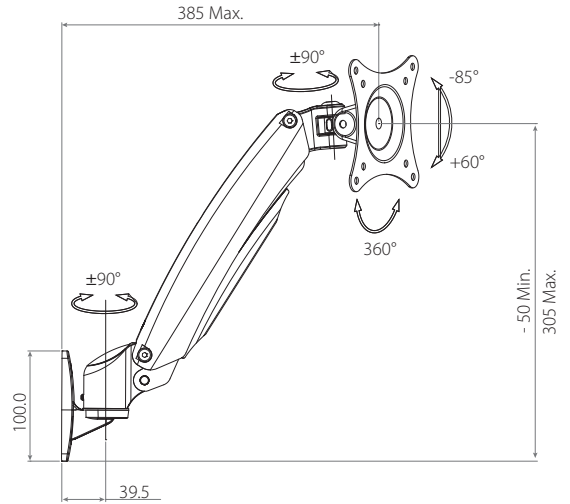

WALL MOUNT APPLICATION

TILT RANGE
+60° to -85°

SWIVEL RANGE
+90° to -90°

SCREEN ROTATION
360°

EXTENSION
385mm

VESA COMPATIBLE
75 X 75 & 100 x 100

SCREEN SIZE
15" to 27"

CONCEALED WIRE MANAGEMENT

LOAD CAPACITY
0kgs/arm

CMA SINGLE EXTENDED ARM WALL MOUNT

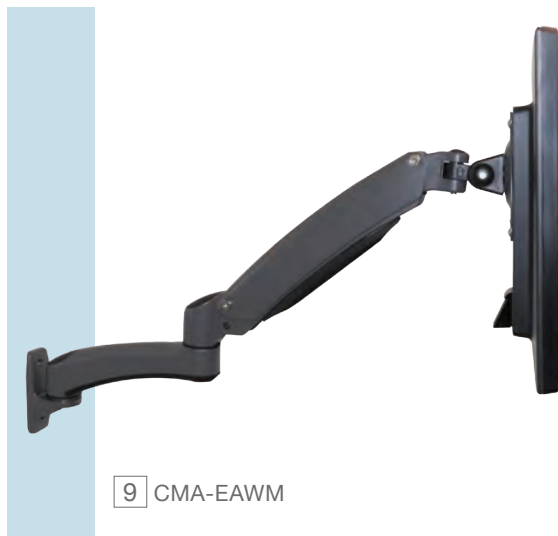

9 CMA-EAWM

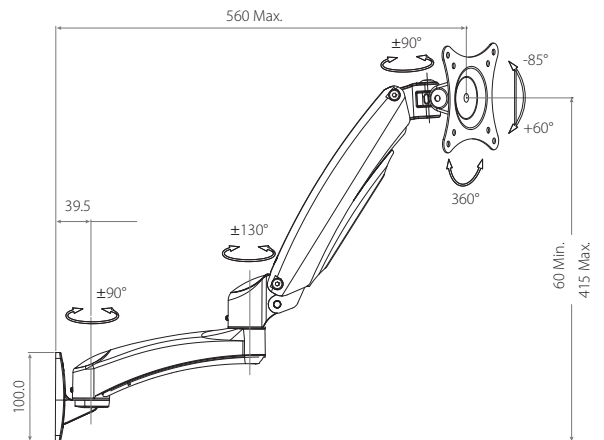

WALL MOUNT APPLICATION

TILT RANGE
+60° to -85°

SWIVEL RANGE
+90° to -90°

SCREEN ROTATION
360°

EXTENSION
560mm

VESA COMPATIBLE
75 X 75 & 100 x 100

SCREEN SIZE
15" to 27"

CONCEALED WIRE MANAGEMENT

LOAD CAPACITY
6kgs/arm

COMPUTER MONITOR ARMS

FLAT SCREEN HOLDERS

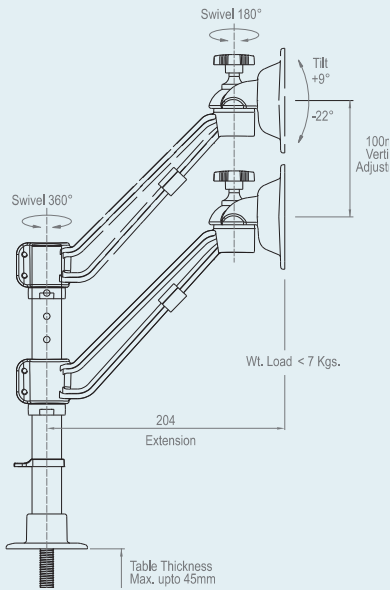

- Flexible left & right movement with tilt up and down feature provides easy monitor view.
- Option of Table Top Grommet mounting and Edge mounting.
- Height Adjustment of 100mm.
- Compatible for VESA 75 x 75 & 100 x 100 with an extra plate.
- Load Capacity : <7Kgs per arm.
- Finish: Black, Silver, White Texture, Anthracite.



SINGLE ARM
1 FSHSA



SINGLE ARM-
EDGE MOUNT
2 FSHSA - EM



SINGLE ARM-
TWIN
3 FSHSAT



DOUBLE ARM
4 FSHDA



DOUBLE ARM -
EDGE MOUNT
5 FSHDA-EM



DOUBLE ARM QUAD
6 FSHDAQ



WALL MOUNT
1 FSHW1



WALL MOUNT
EXTENDED ARM
2 FSHWE2

EXTENSION LINK
(WITH KNOB & SPRINGS)
3 FSH-EL1



- Ideal for wall or partition mounting.
- Can be rotated towards left & right as well as tilted up & down.
- Additional extended arm variant enables to keep the screen away from the wall & provides ample place for rotation.
- Compatible for VESA 75 x 75 & 100 X 100 with an extra plate.
- For TV to Wall distance :
Code FSHW1 - 90mm
Code FSHWE2 - 74 - 190mm
- Finish: Black, Silver, White Texture, Anthracite.

ARTICULATED KEYBOARD STATION W/O MOUSE TRAY

SLIDE, SWING & SWIVEL WITHOUT YOU MOVING

The Worksmart Articulated Keyboard Station is designed to reach you rather than you having to bend or reach for it! Keeping you positioned comfortably at your workstation.

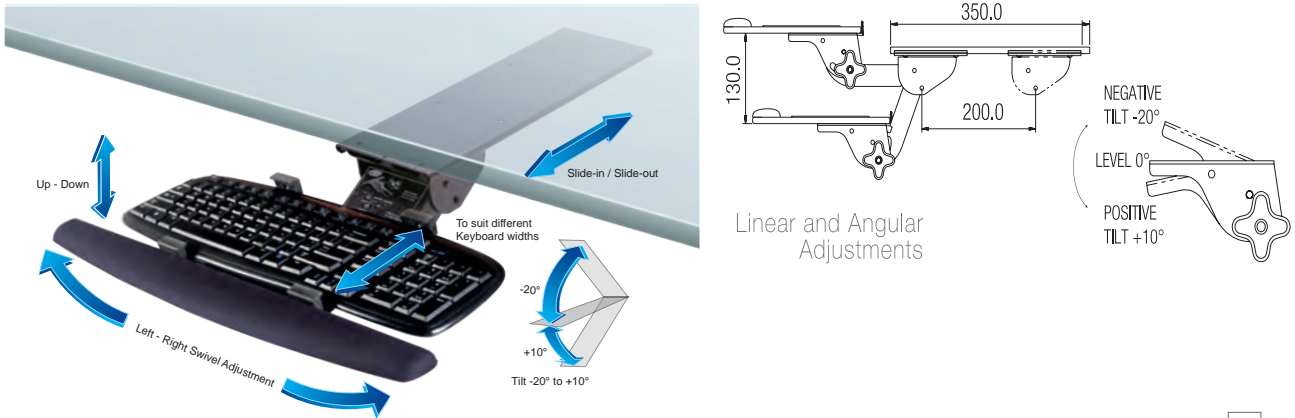

1 AKS1



- Flexible 360° swivel enables user to move keyboard freely as per their sitting posture.
- Available with soft palm rest and stow away softpad to provide rest for your wrists while working.
- Single knob system enables user to adjust height and tilt angle as required (Tilt range: +10° to -20°).
- Keyboard Width : 135-215mm
- Finish: Black, Anthracite.

KEYBOARD TRAYS



KEY BOARD TRAY (350MM)

- 1 KBTM - 35 (With Mouse Tray)
KBT - 35 (Without Mouse Tray)



KEY BOARD TRAY SOFT PAD

- 2 KTSM - 35 (With Mouse Tray)
KTS - 35 (Without Mouse Tray)



KEY BOARD TRAY FULL EXTENSION

- 3 KTS25FE (Without Mouse Tray)

- Unique angled hand rest to prevent fatigue while working.
- Left / right side retractable mouse pad tray.
- Height adjustment on mounting bracket.
- Max. Load: 12 kgs.
- Finish: Black, White Texture

KEYBOARD TRAYS



KEYBOARD TRAY CURVE

- Finish: Black

4 KBTC 35 (Without Mouse Tray)



KEYBOARD TRAY ECO

- Finish: Black

5 KTE1 - 35 (Without Mouse Tray)
KTE1 35M (With Mouse Tray)



KEYBOARD TRAY JUMBO

- Extra-large keyboard tray to place keyboard with mouse.
- Specially designed palm rest with height adjustment on mounting bracket.
- Finish: Black, White Texture

6 KBTJ1



PLASTIC KEYBOARD BASE

- Slides to be ordered separately.
- Suggested to use with Ebco Computer Keyboard Slides.
- Computer Keyboard Slide :
Code : CKDS-45 (Load Capacity : 35Kgs)
CKSE-35 (I) (Load Capacity : 12Kgs)
- Finish: Black

7 PPK1 (With and Without Mouse Tray)
PPKM2 (With Sliding Mouse Tray)

CPU STANDS

SLIMLINE, UNDER-THE DESK, SPACE SAVING



CPU STATION (BASIC)

- Ideal for storage of CPU under the table by adding additional work space.
- Provides quick & convenient access to port and cables without bending your body posture.
- Height Adjustment : 300-550mm
Width Adjustment : 70 - 250mm
- Safe Load: 20 kg.
- Finish: Black, Anthracite.

1 CPUSB

CPU STATION (WITH LOCK & W/O LOCK)

- This comes with an unique locking lever / security lock with key which helps to lock the side locking bracket in place
- CPU can be easily pulled out and swivelled.
- Height Adjustment : 300 - 550mm
Width Adjustment :
W/O Lock : 70 - 250mm
With Lock : 160 - 210mm
- Safe Load: 20 kg.
- Finish: Black, Anthracite.

2 CPUSN 3 CPUSL

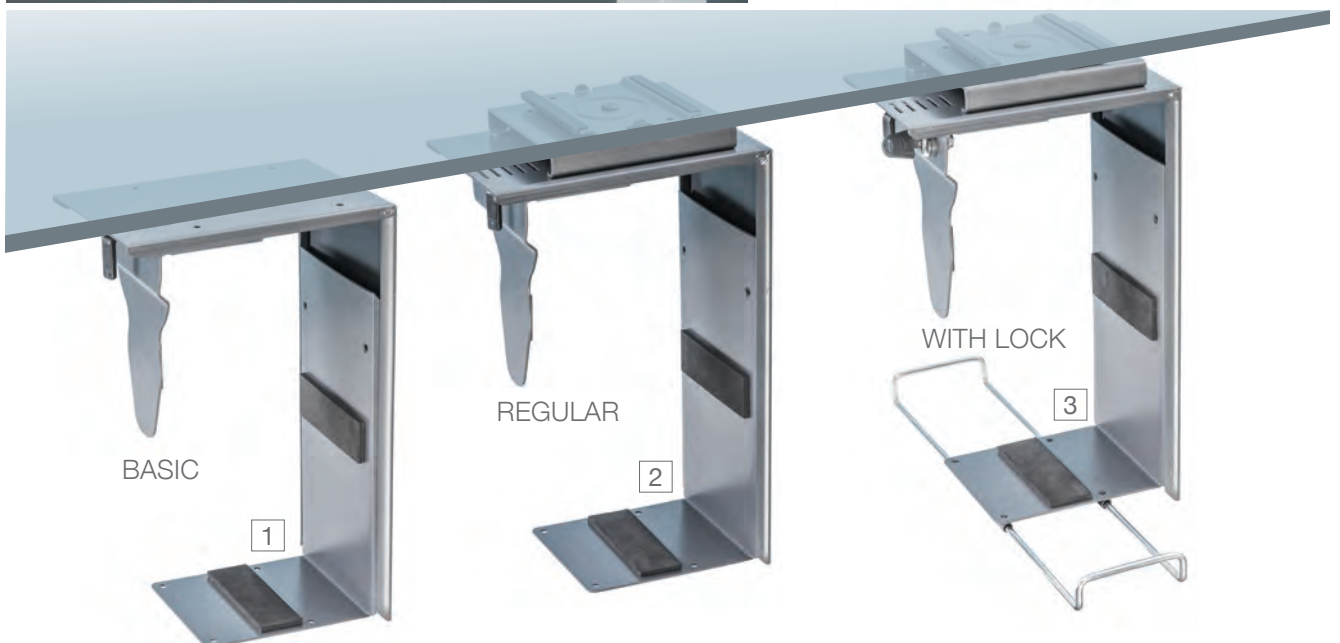

CPU STANDS

TELESCOPIC CPU STAND



4 CPUS1

TELESCOPIC CPU STAND - SLIM



5 CPUS - TS

- Flexible to adjust height & width with special knob feature.
- Height Adjustment : 310 - 530 mm
- Width Adjustment :
Telescopic CPU Stand: 145 - 225 mm
Telescopic CPU Stand Slim: 45 - 100 mm
- CPU Stand Slim model is ideal for storage of compact CPU's.
- Safe Load: 20 kg.
- Finish: Black, Anthracite.

CPU STAND WITH TWIN WHEEL CASTOR



6 CPUS1

CPU STAND ECO



7 CPUS E1

- Provides quick and convenient access to port, drivers, cables etc.
- Protects the unit from dirt, vacuum & other workplace hazards.
- Soft vibration pads provided.
- Width Adjustment :
CPUS1 - 130 - 230mm
CPUS E1 - 100 - 205mm
- Safe Load: CPU Stand – 25 kg ;
CPU Stand Eco – 12 kg
- Finish: For CPUS1 - Anthracite
For CPUS E1 - Black, Anthracite & White Texture

SIDE MOUNTING CPU STAND / SLIM



8 CPUSM



9 CPUSM - S

- Unique knob system below the stand for adjusting the width range without any tools.
- Width Adjustment: Side Mounting CPU Stand: 145 - 225 mm;
Side Mounting CPU Stand Slim: 45 - 100 mm.
- Safe Load: 20 kg.
- Finish: Black, Anthracite.

SAFE DRAWERS

SECURE FOR SURE

- Secure your belongings with ready to use ceiling mount metal safe drawers.
- Equally suitable to use with regular as well as height adjustable desks (Smart Lifts).
- This complete set of drawer with slides, mounting bracket and lock can be retrofitted on your existing tables.
- Safety Mounting Bracket ensures that the drawer cannot be removed as long as it is in locked position.
- Comes with Felt Mat (optional) which keeps the laptop in place, thereby protecting from scratches.
- Available in different variants – Safe Drawer - Top Mount, Safe Drawer – Double, Safe Drawer with Combination Lock, Safe Drawer with Touch Pad Combination Lock
- Finish : Anthracite & White

DRAWER PARTITION FOR SAFE DRAWER

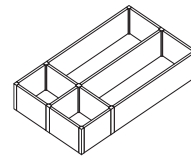

- Organize drawers as desired with flexible drawer partitions.
- Ideal for storing multiple items such as Staplers, Pen, Pencils, Clips or office stationeries.

- Size :298(D) x 165(W) x 48(H) mm
- Finish: Anthracite

SAFE DRAWER - TOP MOUNT - SINGLE (WITH & W/O FELT MAT)

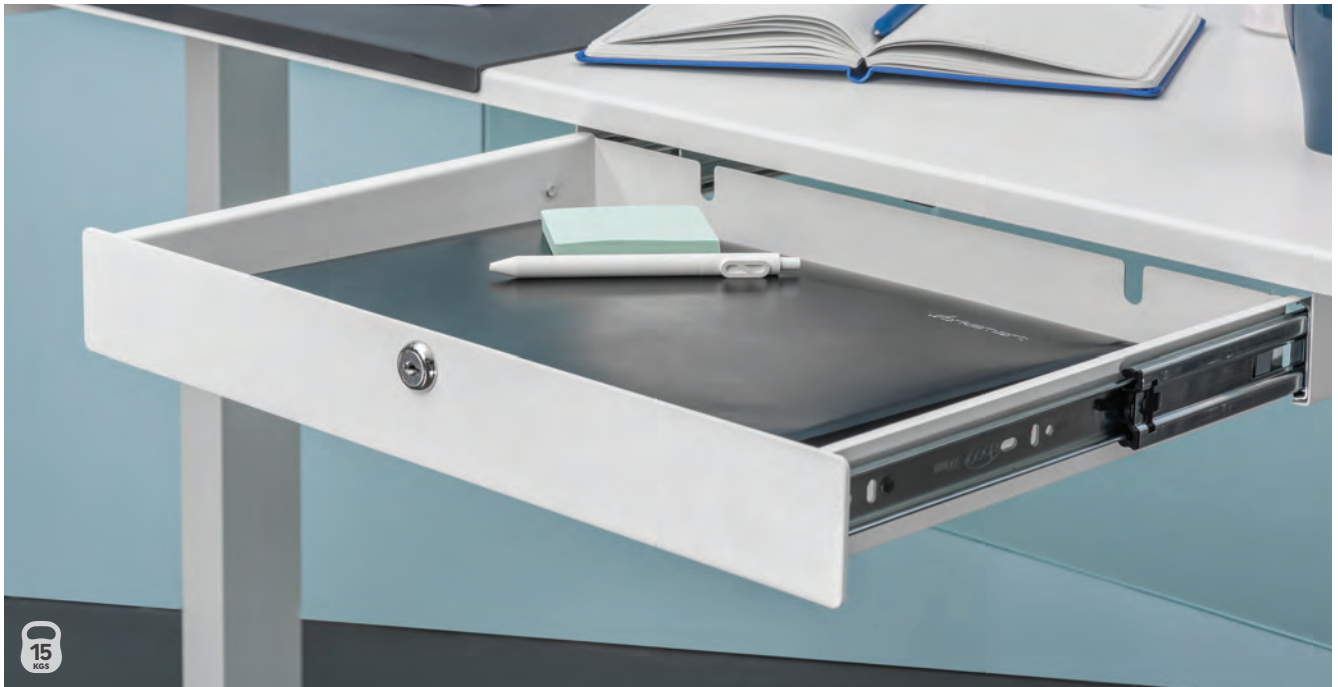

1 SDM-TM1 (With Felt Mat) / SD-TM1 (W/O Mat)

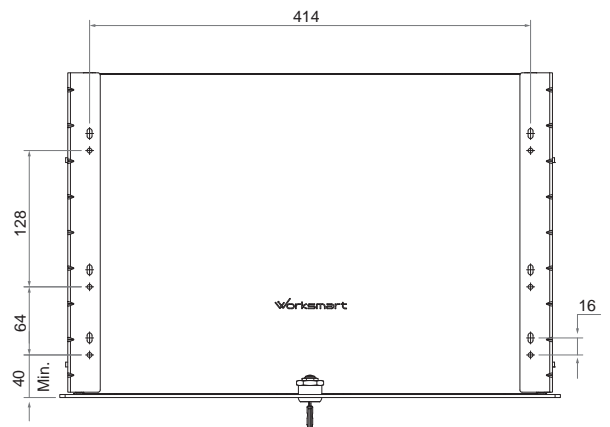
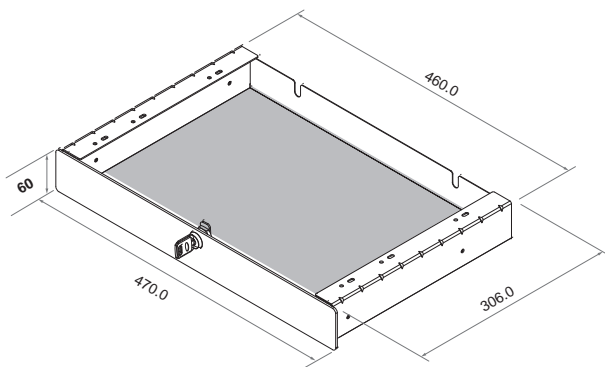

SAFE DRAWER - TOP MOUNT - DOUBLE (WITH & W/O FELT MAT)

2 SDM-TM1D (With Felt Mat) / SD-TM1D (W/O Mat)

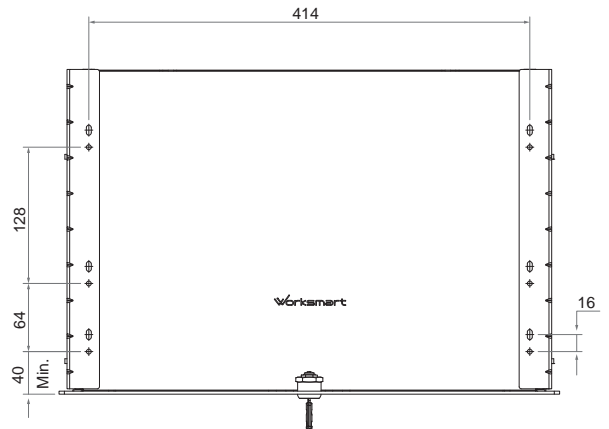
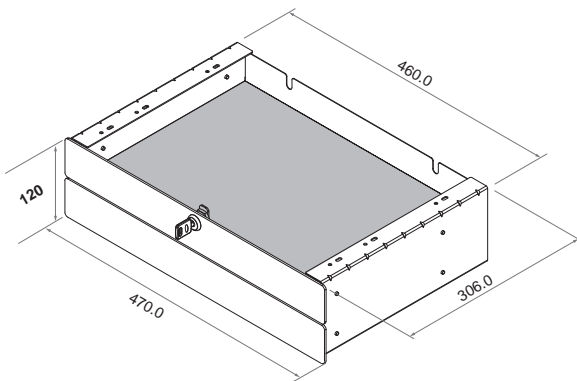

SAFE DRAWER - TOP MOUNT - SINGLE (WITH COMBINATION LOCK & FELT MAT)

3 SDM-TMCL



USER
INSTRUCTIONS

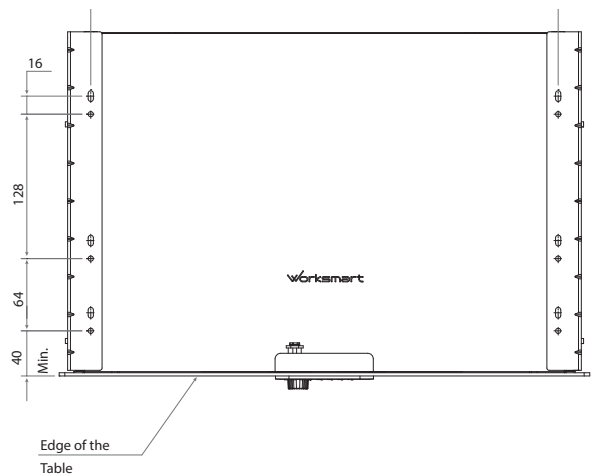
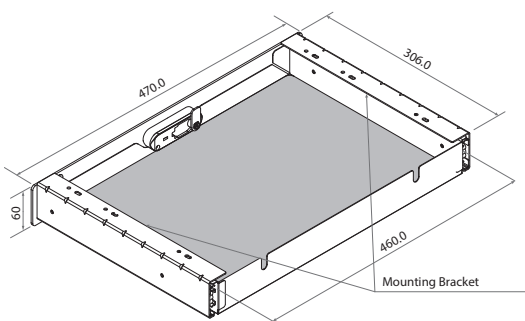

SAFE DRAWER - TOP MOUNT - SINGLE

(WITH TOUCH PAD LOCK & FELT MAT)

4 SDM-TMTPPL



USER INSTRUCTIONS



15 KGS

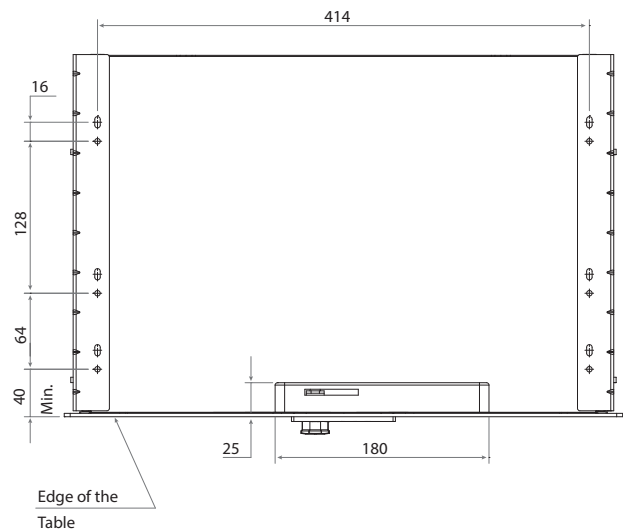
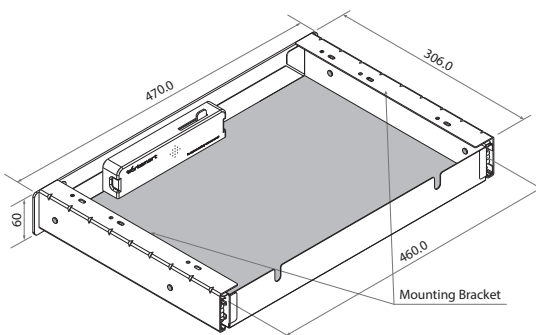

SAFE DRAWER MINI - SINGLE (WITH FELT MAT)

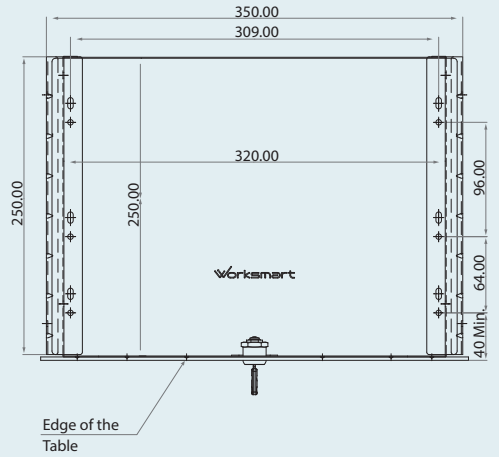

1 SMD-SM1

SAFE DRAWER MINI - DOUBLE (WITH FELT MAT)

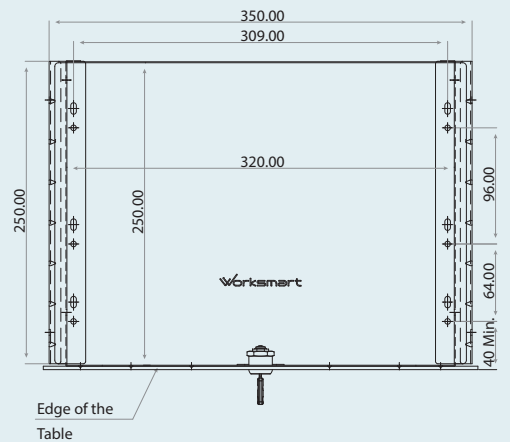

2 SMD-DM1

SAFE DRAWER MINI - SINGLE
(WITH COMBINATION LOCK & FELT MAT)

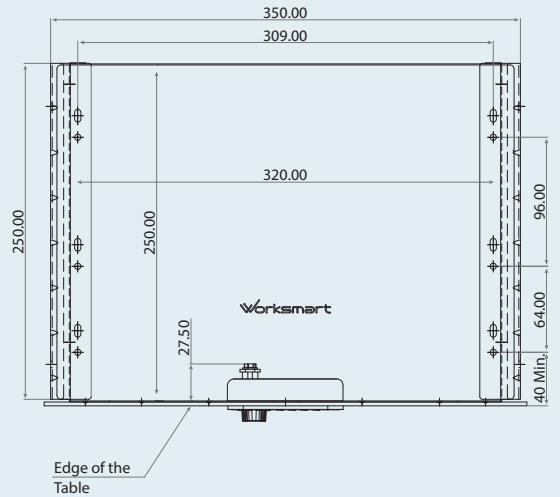

3 SMD-SMCL

SAFE DRAWER MINI - SINGLE
(WITH TOUCH PAD LOCK & FELT MAT)

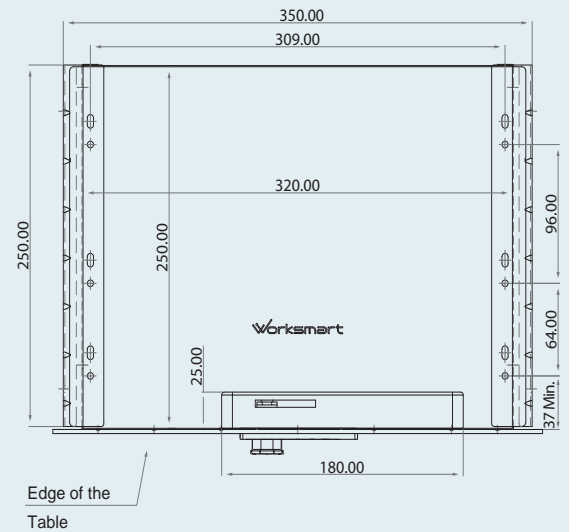

4 SMD-SMTPL

OFFICE FURNITURE ESSENTIALS

WORK STATION TRAY



1 WST - 14-6/ 16-6, Finish: Black

- Ideal for any working or study table.
- Aesthetically designed with both, utility and end user in mind.
- No drawers required as the tray is directly mounted underneath the table.
- Ideal for storing Staplers, Rubbers, Pens, Pencils, Pins, Clips or 2X3 Post it notes.
- 360° rotation for easy accessibility and special catch at 180° for fully closed and open position.
- System 32 Compatible.

WORK STATION TRAY - ROUND



2 WSTR 9, Finish: Anthracite & White

MODESTY PANEL CLAMP



3 MPC1-2-WT / CP



- Provides below work surface modesty for Wood / Glass.
- Can be used for thickness between 4 mm to 12 mm.
- Finish: White Texture, Chrome Plated

TABLE MAT



- Textured black finish with smooth and comfortable resting surface for your work desk.
- Protects your desk from scratches, scuffs or spills of any kind.
- Right angle edge and anti-skid property retains it in position.
- Finish: Black

4 TM 6035

OFFICE FURNITURE ESSENTIALS

TABLE PARTITION CLAMP - SLIM



- Compact and minimalistic glass partition clamp for office table.
- Can be used for wood as well as glass partitions. Available for thickness between 4 - 12 mm & 12 - 20 mm.
- Special plastic pads provided for better grip & protection.
- Finish: White Texture, Silver, Anthracite, Black

5 TPCS - 8 / 16

TABLE PARTITION CLAMP - SLIM EDGE MOUNT



- Suitable for table top edge installation
- Table Top Thickness : 25mm Max.
- For firm support and glass protection, side screws & special plastic pads are provided.
- Finish: White, Silver, Anthracite

6 TPCS-8/16 EM

TABLE PARTITION CLAMP - TOP MOUNT



- Ideal to use for board as well as glass partition.
- Can be used for thickness between 6 – 20mm.
- Side screws and special plastic pads provided for better grip & glass protection.
- Finish: White, Silver.

7 TPC2-620

TABLE PARTITION CLAMP - EDGE MOUNT



- Suitable for table top edge installation
- Table Top Thickness : 25mm Max.
- For firm support and glass protection, side screws & special plastic pads are provided.
- Finish: White Texture, Silver & Anthracite

8 TPC2-620EM

FOOT REST

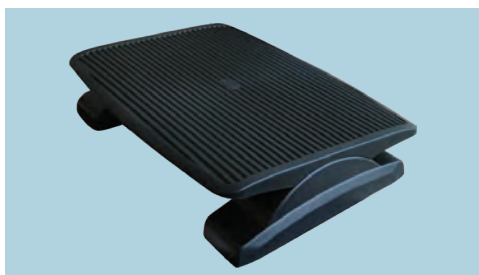

- Designed to keep your feet supported and comfortable keeping the blood circulation regular.
- It can help to prevent varicose veins and pressure on the Achilles tendon which are caused for being seated for long hours.
- Tilts (0° to 20°) to provide the most comfortable angle.
- Non slip surface with large platform base of 450 x 350mm.
- Load Capacity: 20 KG. • Finish: Black

9 FR2

COMPUTER WALL STATION

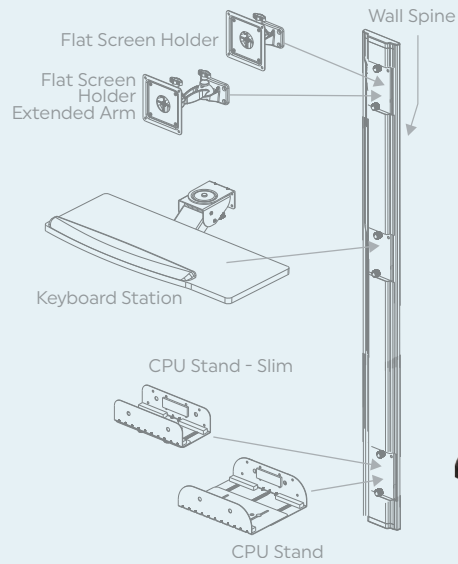

- Modularly designed for all kinds of CPUs, Keyboards & Flat Screens.
- Perfect for limited spaces.
- Height can be adjusted for convenience.
- Ideal to use in hospitals, offices, airports, restaurants etc.
- Available in different optional fittings.
- Finish: White Matt, Anthracite.

1 COMS-1

LAPTOP STAND



2 LTS -1

WORK ON THE GO

- Ergonomically designed laptop stand that can be used on table, in the car, on a bed and in multiple scenarios.
- Lightweight and easy to carry around as per your convenience.
- Anti-skid pad provided to keep your laptop from sliding off the stand.
- Minimizes the risk of modern health hazards such as Carpel Tunnel Syndrome (CTS), Repetitive Stress Injury (RSI).
- Finish: Anthracite.

ELECTRIC BOXES & CHARGERS

EASILY ACCESSIBLE

Worksmart accessories, such as over-the-table and under-the-table integrated charging stations with USB and HDMI slots, partitioned drawers, etc. provide the workstation with easy access to essentials, at arm's length!

ELECTRIC BOX - SLIDE OUT

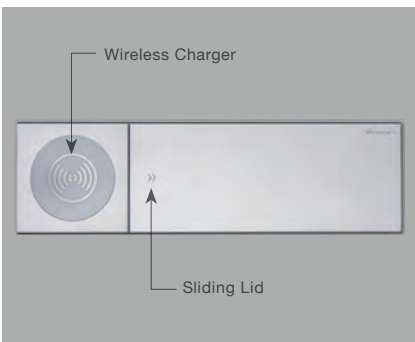

- This concealed electric box is ideal for any conference table, work desk or counter tops.
- Compact and slim design electric box with sliding lid that hides sockets when not in use.
- The unit includes Wireless Charger 10W, 2 Universal Power Sockets, 2 USB Fast Chargers, 1 CAT 6 Socket and 1 HDMI Port.
- Input Voltage : 110 - 250 V, Power : Max. 2300W
- In-built wireless charger for high end smart phones.
- Dimension : 350x100x40mm
- Desktop Cut-out Size : 340x72mm
- Finish - Silver.

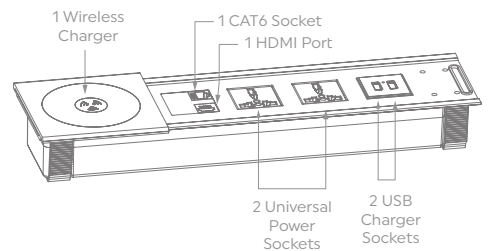
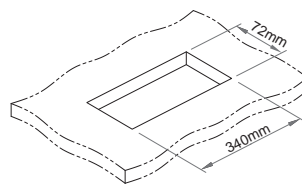

1 EBS - S02

ELECTRIC BOXES & CHARGERS

ELECTRIC BOX WITH CABLE MANAGER 3



- These new Electric Box with cable manager are highly functional and easy to use.
- This compact fitting comes with a special lid that hides the socket when not in use.
- Keeps your cable organized thereby providing clear access to the data / power sockets.
- Available in two variants to choose from.
- Suitable for furniture in offices, conference / meeting rooms, institutional and home applications.
- Input Voltage : 110 - 250 V, Power : Max. 2300W
- Finish : White, Black

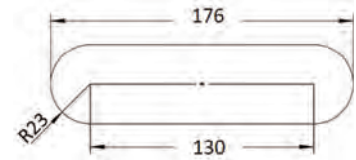

2 EBCM3

Available with 2 USB Charger, 1 Universal Power Socket, Cat 6 and HDMI

ELECTRIC BOX WITH CABLE MANAGER 1 (WITH 1 UNIVERSAL POWER SOCKET)

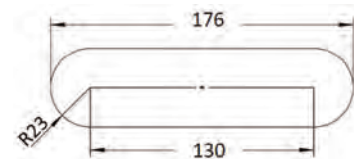

3 EBCM1

Available with 1 Universal Power Socket.

ELECTRIC BOXES & CHARGERS

ELECTRIC BOX - EDGE MOUNT



- Easy edge mounting electric box is ideal for any work desk and portable.
 - Easy clamp on mounting makes it flexible to use on any table and mount anywhere you wish.
 - The unit includes 1 Universal Power Socket, 2 USB Chargers and 1 HDMI.
 - Dimension : 162x43x46mm
 - Input Voltage : 110 - 250 V, Power : Max. 2300W
 - Finish - Black
- 4 EBS - EM2

ELECTRIC BOX - CEILING MOUNT



- Ceiling Mount electric box can be mounted anywhere below the work desks as per your convenience.
- Clutter free desk as it is mounted below the table.
- The unit includes 2 Universal Power Sockets and 2 USB Charger Sockets.
- Ideal for any work desks, conference rooms etc.
- Dimension : 162x43.5x46mm
- Input Voltage : 110 - 250 V, Power : Max. 2300W
- Finish - Black

5 EBS - CM1

ELECTRIC BOXES & CHARGERS

ELECTRIC BOX - FLIP UP



- Unique design with flip up lid that hides sockets when not in use.
- Clutter free desk with no additional wires or cords attached.
- The unit includes
1 Universal Power Socket, 2 USB Fast Chargers,
1 HDMI and 1 VGA.
- Ideal for furniture in Offices, Meeting Rooms, Institutions etc.
- Dimension : 228x158x50mm
- Desktop Cut-out Size: 216x150mm.
- Input Voltage : 110 - 250 V, Power : Max. 2300W
- Finish - Silver

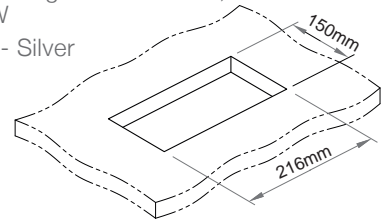

6 EBS - FU2

ELECTRIC BOX SLIM



- Easy access to switches beneath the table.
- Sleek elegant design with built in soft close mechanism.
- Available in six different lengths - 132, 220, 270, 320, 370, 420, 470 mm.
- Finish: White Texture, Anthracite, Black Texture.

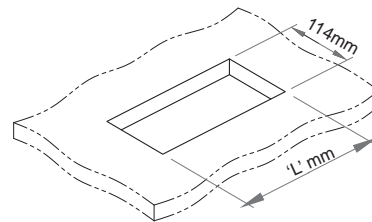

Code	Size 'L'
EBS11	113.0
EBS20	201.0
EBS25	251.0
EBS30	301.0
EBS35	351.0
EBS45	451.0

7 EBS 11-45

ELECTRIC BOX

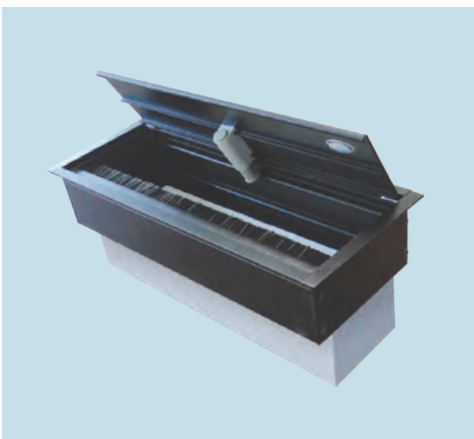

- An integrated workstation solution to add power connectivity to any desks, conference table for multi device charging, connecting projectors etc
- Special lid provided to hide switches when not in use
- Soft Close and Shield (Optional)
- Available in 6, 8, 10 & 12 module
- Finish: White Texture, Anthracite, Black Texture.

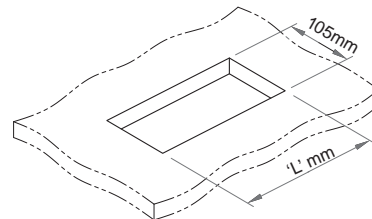

Model	Size 'L'
6 Module	205.0
8 Module	254.0
10 Module	302.0
12 Module	350.0

8 EB-6SMCS

ELECTRIC BOXES & CHARGERS

ELECTRIC BOX BOARD



9 EBB 30 / 45 / 60

- Smart Electric box that gives access to switches beneath a desk/ table.
- Ideal for big adaptors of Laptop, TV, Projector and more.
- Broad design with 3-way access makes it easier to reach the power sockets beneath the table.
- It has a built-in soft close mechanism, which allows the lid to close silently.
- Finish : White

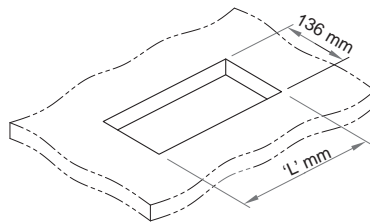

Code	Size 'L'
EBB30	292.0
EBB45	442.0
EBB60	592.0

ELECTRIC BOX SLIM 2



10 EBS230

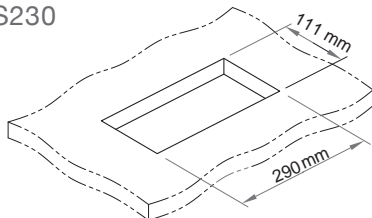

ELECTRIC BOX SLIM 3



11 EBS330 / 345

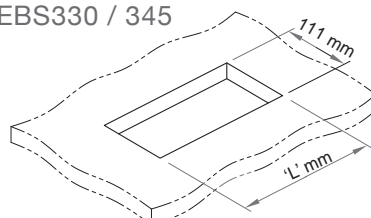

Code	Size 'L'
EBS330	290.0
EBS345	445.0

- Smart Electric box that gives access to switches beneath a desk / table.
- Has a built-in soft close mechanism which allows the lid to close silently.
- Slim 2 : Made of plastic, 3-way access and economic
- Slim 3 : With aluminium lid & sides, 2 way access with cable clip.
- Finish : White

ELECTRIC BOXES & CHARGERS

WIRELESS CHARGER



12 WLC1-WH /BL

- Elegant wireless charger for high end smart phones. Power : 10V
- Can be used with any Micro USB mobile charger.
- Easy to mount in a 60mm dia hole.
- Ideal for furniture in Offices, Meeting Rooms, Intuitional & Home Application.
- Dimension : 80 x 12mm
- Desktop Cut-out Size: 60mm
- Input Voltage : 110 - 250 V, Power : Max. 10W
- Finish - White, Black

USB CHARGER WITH CABLE ORGANIZER DIA 60



13 USBC-CO60

- Dual USB port charger that converts any work desk to a smart charging unit.
- Ideal for any work desk which also functions as cable organiser.
- Physical Dimension : 66x20mm
- Cut-out Size: Ø60mm
- Finish : White, Black

USB CHARGER - FURNITURE MOUNT (LINEAR)



14 USBC-L1

- Dual USB port charger that converts any furniture to smart charging unit.
- Ideal for 18mm & 25mm table tops where it can be recessed on edge/top or mounted beneath the table
- Physical Dimension Size: 80x12x17mm
- Cut-out size:81x13mm (Through Hole)
- USB Output: 5V/2.1A
- AC Adapter: INPUT: AC 100-240v 50/60Hz 0.35 MAX OUTPUT: 5.0 V- 2.0A
- Finish : White, Black

USB CHARGER - FURNITURE MOUNT (CIRCULAR)



15 USBC-C1

- Dual USB port charger that converts any furniture to smart charging unit.
- Ideal for home and Office furniture.
- Size: Ø35x35
- Hole Dia:32mm (Through Hole)
- USB Output: 5V/2.1A
- AC Adapter: INPUT: AC 100-240v 50/60Hz 0.35 MAX OUTPUT: 5.0 V-2.0A
- Finish : White, Black

CABLE ORGANISERS

CABLE ORGANISER Ø20 & Ø30MM



Scan with Smartphone to view Cable Organiser Brochure



BEFORE



AFTER



Neat & Aesthetic



Heat Resistance



Extensive Application



Easy to Replace Cables



Size: Ø20 & Ø30



Flexible & Reusable



Customizable: Cut to size



Black, White & Silver

CABLE ORGANISERS

VERTEBRAE RECTANGULAR / OVAL



Rectangular



Oval

- Ideal for concealing electrical and data cables separately at a work station in an organized way.
- Separate compartments for data & power cables.
- Heavy base allow flexible positioning without drilling on the floor.
- Flexible and unique design with two point joint system.
- Lengths : Rectangular (790mm), Oval (780mm)
- Finish : White, Grey, Black.

2 VR2 (Rectangular) / VO2 (Oval)

CABLE TRAY FIXED



- Ideal for cables management.
- Protects the cables and users.
- Can be fitted easily below the table.
- Rib structure provided for additional strength.
- Width : 384mm
- Finish : White Texture, Anthracite.

3 CTF - 1

CABLE TRAY



- Simple and elegant in appearance.
- Ideal for cables underneath the table.
- Protects cables and users.
- Manufactured out of stainless steel.
- Available in two sizes- 300 & 500 mm.
- Finish: Satin Stainless Steel.

4 CT30/50

CABLE ORGANISERS

UNDERMOUNT CABLE TRAY



5 UCT 551



6 UCT 552

- This new undermount cable tray comes with broader base protect the users from coming in direct contact with cables.
- Ideal for cable management.
- Size : UCT 551 - 550 x 89 x 52mm / UCT 552 - 550 x 180 x 120mm
- Available in two options – Clip and Brackets for easy installation.
- Ideal to suit any type of work stations, conference table, executive tables, etc.
- Finish : White.

CABLE ORGANIZER - DIA-60



7 CO60

- Unique design with 3 port selection to suit different number of cables.
- Manufactured out of plastic.
- Finish: White, Grey, Black.

CABLE ORGANIZER - ZINC



8 C060/80 ZN1

- Die Cast and Zinc Plated.
- Available in grommet size of Ø60 and Ø80.
- Finish: Zinc White.



Our products are easily available through a network of 29 Authorized Distributors, which supply more than 5,000 dealers and hardware shops around the country. We have number of exclusive product display centers around the country – one in every major city of India and new ones opening every year. These are consistently updated to exhibit the latest additions to our ever-widening range; and provide venues for product training and after sales support for installation.



- BROCHURES
- LEAFLETS
- CATALOGUES